

GBV-A

Balancing Valves

Ductile Iron ASTM A536, Grade 65-45-12

The Series GBV is a multi-turn, Y-style globe valve designed for accurate determination and control of fluid flow to circuits requiring precise balancing.

Max. Working Pressure
300 PSI / 20.7 bar (PN20)

Max. Working Temperature
230°F (110°C)



Straight Shown

FEATURES & BENEFITS

- Pressure differential ports on both sides of the valve
- Convertible design, straight to 90° angle by removing and replacing four set screws
- Positive shutoff for equipment servicing
- Multi-turn adjustment
- Ergonomically designed handwheel
- Micrometer type adjustment scale
- Tamper-proof hidden memory stop

MATERIAL SPECIFICATIONS

BODY, BONNET: Ductile Iron ASTM A536, Grade 65-45-12

STEM & DISC: Brass Alloy B16

ELASTOMERS: EPDM

HANDWHEEL: Reinforced Nylon; ABS

GBV-A – Balancing Valve

2 1/2" to 12" Ductile Iron, Grooved-End or Flanged-End Angle

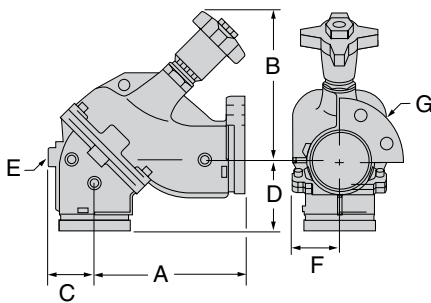

**FIGURE GBV-A GROOVED-END ANGLE BALANCING VALVES
DUCTILE IRON, GROOVED-END OR FLANGED-END ANGLE**

Nominal Size	O.D.	A	B Open	C	D	E	F	Flange Diameter		Approx. Wt. Each
								G Flange 125#	G Flange 250#	
In./DN(mm)	In./mm	In./mm	In./mm	In./mm	In./mm	In./mm	In./mm	In./mm	In./mm	Lbs./Kg
2 1/2 65	2.875 73.0	7 3/8 187	9 5/8 244	2 3/4 70	4 5/8 117	1 25	2 9/16 65	7 178	7 1/2 191	25 11.3
3 80	3.500 88.9	8 3/16 213	10 1/2 267	2 7/16 61	3 7/8 98	1 25	3 76	7 1/2 191	8 1/4 210	28 12.7
4 100	4.500 114.3	9 5/8 244	10 9/16 268	3 76	4 3/8 111	1 1/4 32	3 7/16 87	9 1/4 235	10 254	41 18.6
5 125	5.563 141.3	12 305	13 1/16 331	3 5/8 92	5 1/2 140	1 1/4 32	4 15/16 125	10 254	11 279	90 40.8
6 150	6.625 168.3	14 1/8 359	13 3/4 349	4 7/16 112	6 5/8 168	2 51	5 7/8 149	11 279	12 1/2 318	130 59.0
8 200	8.625 219.1	18 15/16 481	24 5/8 625	5 1/16 144	9 9/16 233	2 1/4 57	7 7/8 200	13 1/2 343	15 381	310 140.6
10 250	10.750 273.1	20 5/16 515	26 1/2 673	6 9/16 166	9 3/4 248	2 1/4 57	9 15/32 240	16 406	17 1/2 445	460 208.7
12 300	12.750 323.9	24 1/16 611	28 7/16 722	7 5/8 194	14 356	2 1/4 57	12 5/8 321	19 483	20 1/2 521	870 394.6

NOTE: Grooved-Ends are for connection of components with dimensions conforming to Gruvlok® standard grooved specifications for IPS pipe. See www.anvilintl.com for installation instructions and flow data.

PROJECT INFORMATION

APPROVAL STAMP

Project:	<input type="checkbox"/> Approved
Address:	<input type="checkbox"/> Approved as noted
Contractor:	<input type="checkbox"/> Not approved
Engineer:	Remarks:
Submittal Date:	
Notes 1:	
Notes 2:	

GBV-A

Balancing Valves

1.0 INSTALLATION

1.1 To ensure accuracy of measurement, the GBV should be located at least five pipe diameters downstream from any fitting, and at least ten pipe diameters downstream from a pump. Two pipe diameters downstream from the GBV should be free of any fitting (as illustrated in Figure 1).

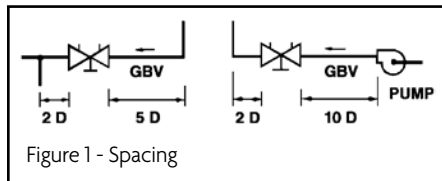

- 1.2 GBV valves must be installed with flow in the direction of the arrow of the valve body. Easy access to the probe metering ports (P.M.P's) and handwheel must be provided.
- 1.3 GBV valves can be installed in horizontal or vertical piping. The metering ports should never be installed below the pipe (pointing down), as this will allow system sediment to accumulate in the ports. (Illustrated below for horizontal piping in Figure 2.)

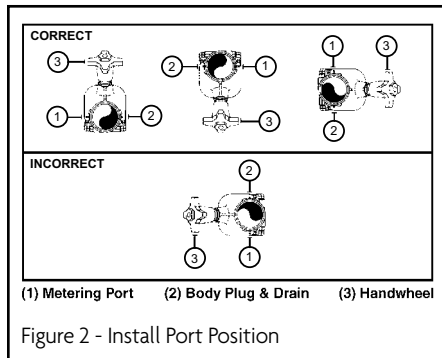

- 1.4 GBV angle-style valves are designed to replace piping elbows.
- 1.5 Metering ports and body plugs may be interchanged for improved accessibility.

2.0 FLANGE ADAPTERS

2.1 The Fig. 7012 Gruklok Flange Adapter can be used with the GBV Balancing Valves. Installation is similar to the installation of the Figure 7012 with grooved pipe.



2.2 Loosen the nut on the latch bolt to the end of the bolt thread. (It is not necessary to remove the nut from the latch bolt.) Swing the latch bolt out of the slot. Open the Gruklok Flange and place it around the grooved tube with the key section fitting into the groove. The flange gasket cavity must face the tube end.



2.3 Swing the latch bolt back into the slotted hole. Tighten the nut until the flange halves make solid contact.



2.4 Check the gasket grade to verify that it is properly suited for the intended service. Lubricate the entire surface of the gasket and the flange gasket cavity using Gruklok lubricant. Position the Gruklok Flange Gasket around the tube end and press the gasket into the cavity between the tube O.D. and the flange recess. The gasket must be properly positioned as shown in Step 2.5. Be careful that foreign particles do not adhere to lubricated surfaces.



2.5 The correct positioning and relationship of all components comprising a Gruklok Flange joint. The Fig. 7012 Gruklok Flange gasket must be inserted so that the sealing lips face toward the tube end and the mating flange face and away from the Gruklok Flange itself.

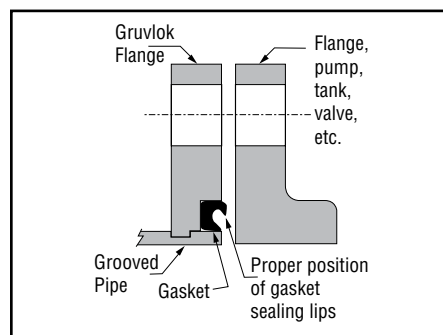

NOTE: Design of the Gruklok Flange provides sealing only with the special Gruklok Flange gasket. Only Gruklok Flange gaskets may be used with Fig. 7012 Gruklok Flanges.

2.6 Align the Gruklok Flange bolt holes with the mating flange bolt holes. Insert a standard bolt or stud through the bolt hole, and thread a nut on hand tight. Insert the next bolt or stud opposite the first and again thread the nut on hand tight. Continue this procedure until all holes have been fitted.



NOTE: Take care to assure that the gasket lip is not bent backwards or pinched between the two flanges.

2.7 Tighten the nuts evenly so that the flange faces remain parallel and make firm even contact around the entire flange. Torque all bolts to required flange joint torque levels.



3.0 CONVERSION (STRAIGHT TO ANGLE)

- 3.1 Open the valve one complete turn.
- 3.2 Remove the body bolts from the valve body.
- 3.3 Rotate one-half of the valve body, 180°, making sure the seat and the "O" ring stay in position and does not get nicked or cut.
- 3.4 Replace the body bolts and tighten evenly.

4.0 OPERATION

4.1 The valve operates from closed (Figure 4) to partially open (Figure 5) to fully open (Figure 6) by a counterclockwise rotation of the orange handwheel, using five 360° turns for the 2-1/2" and 3" valves, six turns for the 4", 5" and 6" valves, 12 turns for the 8" and 10" valves and 14 turns for the 12" valve. The position of the valve is indicated by two scales.

Inner Scale (Figure 6) - This sleeve has a vertical arrowed scale which indicates the number of full turns the valve has been opened.

Outer Scale (Figure 6) - This scale is a micrometer type scale marked 0-9 at the tapered base of the orange handwheel. Each gives 1/10th indications for each 360° turn of opening against the indicator line of the Inner Scale.

GBV-A

Balancing Valves

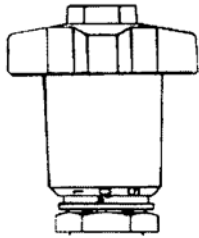

Figure 4 – With no arrows visible, the Inner Scale set at 0 on the indicator line aligned with the 0 on the Outer Scale; the valve is closed.

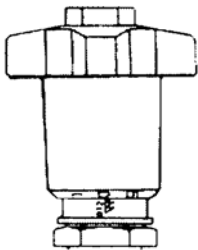

Figure 5 – Shows a valve setting of 2.0, indicating that the valve is partially open.

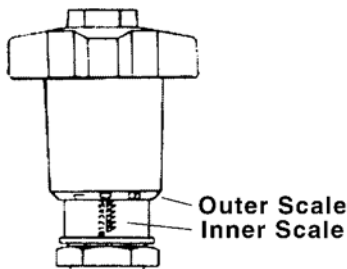

Figure 6 – With all arrows visible, the Inner Scale, set at 6 and the indicator line aligned with Outer Scale 0; the valve setting is 6.0 and the valve is fully open.

Connect meter quick-disconnect hoses to metering ports as follows:

- Remove protective cap from metering ports
- Insert and lock the meter probe into the metering ports

4.2 The hose with the orange fitting upstream; the hose with the blue fitting, downstream.

4.3 **CAUTION:** The probe should not be left inserted into the fitting for prolonged periods of time; overnight, etc., as leakage of the P.M.P. may occur when the probe is removed.

The locking nut on the probe is designed to hold it in the P.M.P. when taking readings in systems having a high working pressure. As sealing is accomplished internally on the probe stem, it is only necessary to tighten

the locking nut finger-tight. Over-tightening may cause damage to the P.M.P. or locking nut threads.

4.4 Safety glasses should be used.

4.5 Before taking a flow measurement reading, set the valve to its fully open (4.0) or at a preset position. Read the pressure drop across the valve with a pressure differential meter. Determine GPM flow by use of valve CV curve on page 5.

5.0 MEMORY SETTING (Figure 7) 2 1/2" - 6" Valves

5.1 After the valve has been adjusted to its balance set point and without moving the handwheel, remove the retaining bolt from the end of the handwheel using a 1/4" Allen wrench.

5.2 Carefully remove the handwheel and turn indicator sleeve assembly, leaving the valve at its balance set point.

5.3 Turn the plastic memory stop (clockwise) down until it stops. Finger-tight pressure is sufficient. **DO-NOT-OVERTIGHTEN.**

5.4 Holding the memory stops in position, turn the lock collar (clockwise) down until it stops against the valve bonnet. The memory has now been set.

5.5 With the handwheel/turn indicator sleeve assembly still at its balance set point indication, reinstall them on the valve stem and hold in place with the 1/4" retaining bolt.

CAUTION: Care must be taken not to rotate the valve stem or change the handwheel/indicator setting while setting the memory.

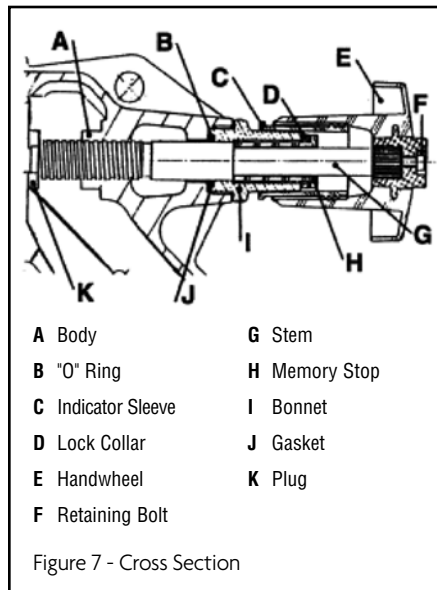

6.0 MEMORY SETTING (Figure 7) 8" Valves and Larger

6.1 After the valve has been set to the correct balance point, record the setting. Without turning the handwheel, remove the retaining bolt from the end of the handwheel.

6.2 Carefully remove the handwheel. Slight tapping with a mallet may be required but do not change the valve stem position.

6.3 Turn the brass memory lock ring until the aluminum memory ring stop contacts the step on the valve stem. **DO NOT OVERTIGHTEN.** Finger-tight pressure is sufficient.

6.4 Reinstall the handwheel in the correct orientation so that the original setting is indicated and secure with the retaining bolt.

7.0 REPOSITIONING HANDWHEEL 2 1/2" - 6" Valves

7.1 The handwheel can be removed and repositioned in any of six positions around the stem.

a) Close valve fully.

b) Remove handwheel retaining bolt.

c) Remove handwheel and turn indicator sleeve by grasping the handwheel and pulling away from the valve body along the stem.

d) Select a new position for easy reading and, with the sleeve and handwheel held together in the closed position (0.0), push them back over the bonnet head and valve stem.

e) Replace handwheel retaining bolt.

f) Open valve.

7.2 If handwheel is removed for any reason, it is important to first close the valve, and then replace the handwheel per 7.1d) and 7.1e), above.

8.0 REPOSITIONING HANDWHEEL 8" Valves and Larger

8.1 The handwheel can be removed and repositioned in any of six (6) positions around the stem.

a) Close valve fully.

b) Remove handwheel retaining bolt

c) Remove handwheel by grasping handwheel and pulling away from the valve body along the stem. Slight tapping with a mallet may be required.

d) Select a new position for easy reading of the scale and reinstall the handwheel with the

GBV-A

Balancing Valves

"0" mark located at the bottom pointed in this direction. Secure with the retaining bolt.

e) Loosen the scale retaining ring and rotate the turn indicator scale to align with the "0" on the handwheel. Tighten the scale retaining ring by hand. **DO NOT OVERTIGHTEN.**

f) Open the valve.

9.0 REPACKING GBV UNDER FULL SYSTEM PRESSURE

2 1/2" - 6" Valves

- 9.1 Open valve fully to its memory setting and, on a piece of paper, record the valve setting.
- 9.2 Remove the handwheel/indicator sleeve assembly as per 5.1 and 5.2.
- 9.3 Loosen the lockcollar by turning it counter-clockwise until it seats against the top of the memory stop.
- 9.4 Remove the memory stop/lockcollar assembly by turning the plastic memory stop counter-clockwise.
- 9.5 Using the handwheel WITH THE INDICATOR SLEEVE REMOVED, turn the valve stem counter-clockwise until the valve is fully open and will not turn any further (45 ft. lbs.). A step on the valve plug has now been back-seated against the upper portion of the valve body (metal-to-metal).
- 9.6 The valve bonnet may now be removed. There may be slight leakage, as the metal-to-metal backseating does not provide a drip-tight seal.
- 9.7 Clean exposed portion of valve stem **(Do not scratch)**.
- 9.8 Remove and replace the "O" ring and gasket.
- 9.9 Install the valve bonnet.
- 9.10 Replace memory stop/lockcollar assembly into the valve bonnet.
- 9.11 Close the valve fully by turning the stem in a clockwise direction
Tightening valve bonnet is necessary to stop any leaks.
- 9.12 Replace handwheel/indicator sleeve assembly per 7.1 d) and e), previous page.
- 9.13 Open valve to balance set point as recorded in 9.1.
- 9.14 Reset memory per 5.0

10.0 REPACKING GBV UNDER FULL SYSTEM PRESSURE

8" Valves and Larger

- 10.1 Open the valve fully to its memory setting and, on a piece of paper, record the valve setting.
- 10.2 Remove handwheel as per 6.1 and 6.2.
- 10.3 Loosen scale retaining ring and remove turn indicator assembly. It is not necessary to change the memory set point.
- 10.4 Using the handwheel, turn the stem counterclockwise until it stops (50 ft.lbs.). A step on the stem has now been back-seated against the upper portion of the valve body.
- 10.5 The valve bonnet may now be removed. There may be slight leakage as the back seat does not provide a drip-tight seal.
- 10.6 Clean exposed portion of valve stem. **(DO NOT SCRATCH)**.
- 10.7 Remove and replace the "O" ring and gasket.
- 10.8 Install the valve bonnet. Torque to 70 ft. lbs.
- 10.9 Close valve fully.
- 10.10 Reinstall turn indicator assembly. Scale retaining ring should be hand-tight. **DO NOT OVERTIGHTEN.**
- 10.11 Reinstall handwheel and secure with retaining bolt.
- 10.12 Open valve to balance set point as recorded.

GBV-A

Balancing Valves

