

MODEL 768G

Grooved-end “Wye” Strainer

Grooved-end Wye-Strainers are designed to strain debris and foreign matter from piping systems and thus provide inexpensive protection for costly pumps, meters and other components. The Strainer can be installed quickly and easily with two mechanical couplings and the straight flow through design provides for lower pressure drop. This strainer features a stainless steel screen that is secured with an end cap and mechanical coupling. Cleaning and maintenance of the screen can be accomplished easily by removing the coupling. The Strainer is suitable for vertical and horizontal installations.

MATERIAL SPECIFICATIONS

BODY: Ductile iron ASTM A 536 Grade 65-45-12

END CAP: Ductile iron ASTM A 536 Grade 65-45-12

SCREEN:

- 2" - 3" Type 304 Stainless Steel to ASTM A 240
1/16" (1.6 mm) perforations (12 mesh)
- 4" - 12" Type 304 Stainless Steel to ASTM A 240
1/8" (3.2 mm) perforations (6 mesh)

COUPLING: Ductile iron ASTM A 536 Grade 65-45-12

GASKET:

- EPDM Temperature range -40°F - +230°F (-40° to 110°C) - Standard
- Nitrile Temperature range -20°F to 180°F (-29° to 82°C) - Special Request

BLOW DOWN PORT:

- 2"- 5": 1" tapped with plug,
- 6" - 12": 1 1/2" tapped with plug

Strainer baskets need a routine maintenance program to maintain efficiency and to prevent excess pressure drop caused by a clogged screen.



Values for flow of water at +60°F (+16°C)

$$C_v = \frac{Q}{\sqrt{\Delta P}}$$

Where:
 Q = Flow (GPM)
 C_v = flow coefficient
 ΔP = Pressure drop (PSI)

PROJECT INFORMATION		APPROVAL STAMP	
Project:		<input type="checkbox"/> Approved	
Address:		<input type="checkbox"/> Approved as noted	
Contractor:		<input type="checkbox"/> Not approved	
Engineer:		Remarks:	
Submittal Date:			
Notes 1:			
Notes 2:			

MODEL 768G

Grooved-end “Wye” Strainer

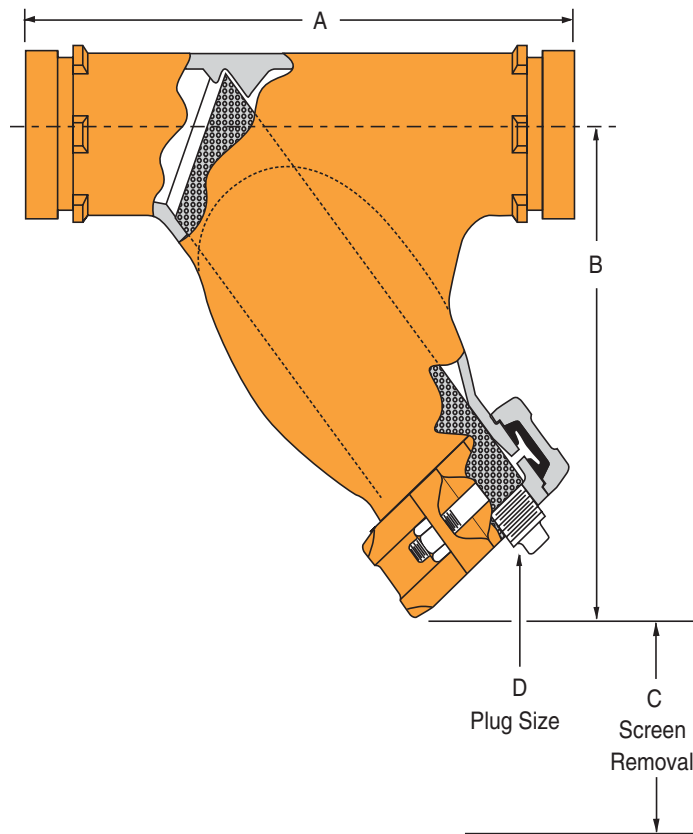

FIGURE 768G GROOVED-END “WYE” STRAINER								
Nominal Size	O.D.	Working Pressure	Dimensions				Cv Values	Approx. Wt. Each
			A	B	C	D Plug Size		
In./DN(mm)	In./mm	PSI/bar	In./mm	In./mm	In./mm	In./mm		Lbs./Kg
2	2.375	300	9 ³ / ₄	6 ³ / ₄	4 ⁷ / ₈	1	59	11
50	60.3	20.7	248	171	124	25		5.0
2½	2.875	300	10 ³ / ₄	7 ³ / ₈	5¼	1	92	14
65	73.0	20.7	273	187	133	25		6.4
3	3.500	300	11 ³ / ₄	8 ³ / ₁₆	5 ⁷ / ₈	1	162	20
80	88.9	20.7	298	208	149	25		9.1
4	4.500	300	14¼	10	7½	1	284	32
100	114.3	20.7	362	254	191	25		14.5
5	5.563	300	16½	11¼	8¼	1	410	46
125	141.3	20.7	419	286	210	25		20.9
6	6.625	300	18½	13 ³ / ₈	9 ⁷ / ₈	1½	770	70
150	168.3	20.7	470	340	251	38		31.8
8	8.625	300	24	16 ³ / ₄	12 ⁵ / ₁₆	1½	1010	155
200	219.1	20.7	610	425	313	38		70.3
10	10.750	300	27	19	13 ¹¹ / ₁₆	1½	1800	230
250	273.1	20.7	686	483	348	38		104.3
12	12.750	300	30	22 ¹⁵ / ₁₆	16 ¹¹ / ₁₆	1½	2800	335
300	323.9	20.7	762	583	424	38		152.0

Not for use in copper systems.

- Pressure ratings listed are CWP (cold water pressure) or maximum working pressure within the service temperature range of the gasket used in the coupling. This rating may occasionally differ from maximum working pressures listed and/or approved by UL, ULC, and/or FM as testing conditions and test pipes differ.
- Maximum working pressure and end loads listed are total of internal and external pressures and loads based on Sch. 40 steel pipe with roll grooves to ANSI C606-97 specifications.
- For one time field test only the maximum joint working pressure may be increased 1½ times the figures shown.
- Warning: Piping systems must always be depressurized and drained before attempting disassembly and or removal of any components.