

Fig. 439: Structural "H" Slide Assembly

Fig. 439A: Structural "H"

Pipe Slide Assembly, Complete

Size Range: 6" through 36"

Material: Carbon steel "H" section, PTFE bonded slide plates and carbon steel base.

Finish: Plain, Painted or Hot-Dip Galvanized (Welded after Galvanizing and Cold Spray Touched-up)

Service: A heavy duty slide support where horizontal movement resulting from expansion and contraction takes place and where a low coefficient of friction is desired.

Approvals: Complies with Federal Specification A-A-1192A (Type 35), ANSI/MSS SP-69 and MSS SP-58 (Type 35).

Maximum Load: As indicated at 70° F see page 135 for rating factor at higher temperatures.

Maximum Temperature: 750° F

Temperature Range at PTFE: -20° F to 400° F

Features:

- No lubrication required.
- Allows up to 4" of insulation.
- Allows up to 10" travel standard.
- Weld in place design.

Available Options:

- Increased travels.
- Increased "H" Section heights.
- Clamps, Fig. 212 or Fig. 432.
- Base plate with mounting holes. The bolt spacing for the bolted base plates is equal to the "W" dimension minus 1 1/2" and the "BL" dimension minus 1 1/2" for all pipe sizes and the hole diameter is 9/16" for all sizes.

Ordering: Specify figure number, type, name, finish and any other option desired.

Notes: Types 1, 2, and 3 provide for longitudinal movement only. Types 4 and 5 provide for both longitudinal and transverse movement of piping.

PTFE Pipe Slide Assembly – "H" Type

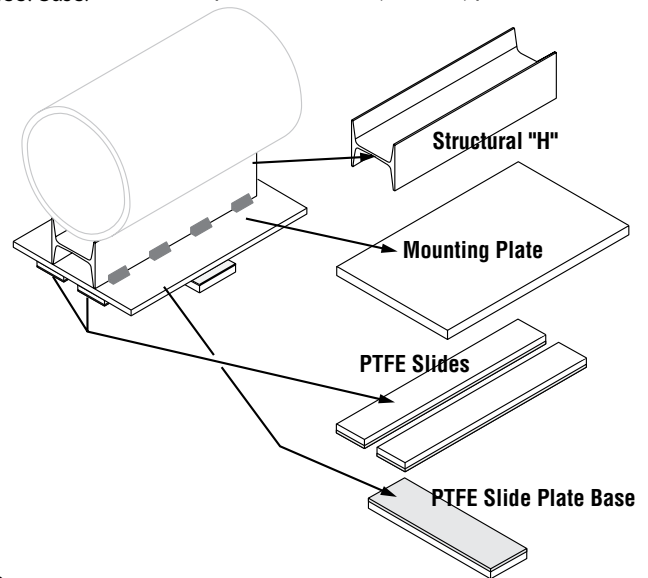

Note: In the PH-92 and PH-92R Catalogs:

The Fig. 439 (slide "H" section only) formerly referred to as Fig. 437. The Fig. 439 (slide base plate) formerly referred to as Fig. 438 (slide base plate).

The acceptability of galvanized coatings at temperatures above 450°F is at the discretion of the end user.

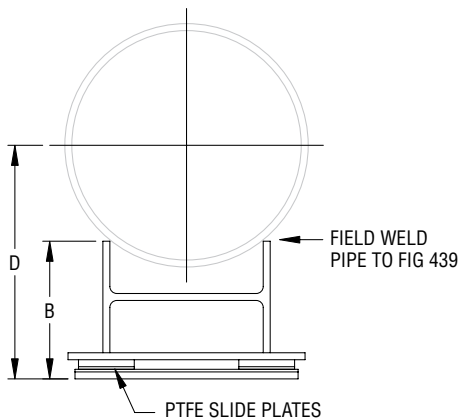

FIG. 439: LOADS (LBS) • DIMENSIONS (IN)

Pipe Size	B			D *			Max Load		
	Type			Type			Down	Side Type 2, 3, 5	Up Type 3
	1 & 4	2 & 5	3	1 & 4	2 & 5	3			
6	5	5 1/4	5 5/16	7 3/4	8	8	12,000	3,000	1,200
8				8 3/4	9	9			
10				9 5/8	9 7/8	9 15/16			
12	5 1/8	5 3/8	5 7/16	10 3/4	11	11 1/16	16,000	4,000	1,600
14				10 7/8	11 1/8	11 3/16			
16				12 1/8	12 3/8	12 7/16			
18				12 5/8	12 7/8	12 15/16			
20				13 3/4	14	14 1/16			
24	5 1/4	5 1/2	5 9/16	15 5/8	15 7/8	15 15/16	24,000	6,000	2,400
30	6 1/4	6 5/8	6 11/16	19 5/8	19 7/8	20 1/16			
36	6 7/16	6 13/16	6 3/4	23	23 1/4	23 7/16			

* With clamps; add material thickness of a Fig. 212 for bolted bases add 5/16" to height "H" dimension.

** With the Figure 432 special clamp, add the material thickness of Figure 432.

PROJECT INFORMATION		APPROVAL STAMP	
Project:		<input type="checkbox"/> Approved	
Address:		<input type="checkbox"/> Approved as noted	
Contractor:		<input type="checkbox"/> Not approved	
Engineer:		Remarks:	
Submittal Date:			
Notes 1:			
Notes 2:			

Fig. 439

Structural "H" Slide Assembly, Complete

WELDED: DIMENSIONS (IN)						
Pipe Size	W Type				BL Type	
	1	2 & 3	4	5	1 & 4	2, 3, & 5
	6	5 1/2	10	7 1/2	10	2
8						
10						
12	8	12 1/2	10 1/2	12 1/2		
14						
16						
18	10	14 1/2	12 1/2	14 1/2		
20						
24						
24	12	17	14 1/2	17	3	
30						
36						

BOLTED: DIMENSIONS (IN)				
Pipe Size	W Type 1 to 5	BL Type 1 to 5	Hole Spacing	
			C	G
6	10	6	8 1/2	4 1/2
8				
10			12 1/2	
12				
14	14 1/2			
16				
18		17	15 1/2	
20				
24	17 1/2			
30	19	19 1/2		
36	21	21 1/2		

WELDED SCHEMATICS

BOLTED SCHEMATICS

Type 1

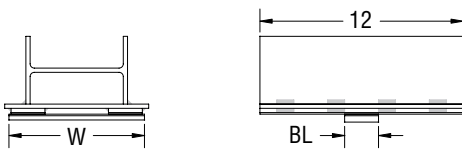

Type 1

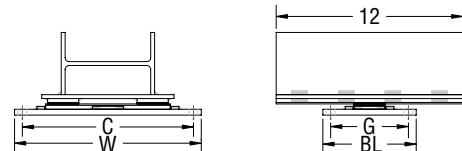

Type 2

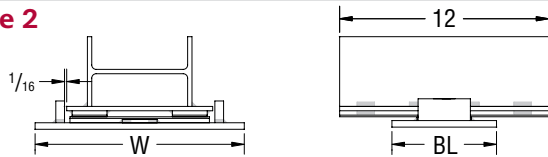

Type 2

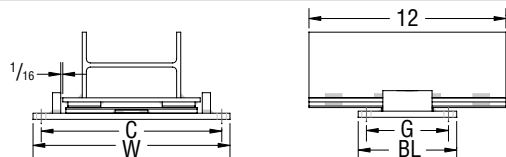

Type 3

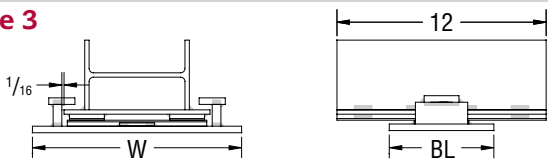

Type 3

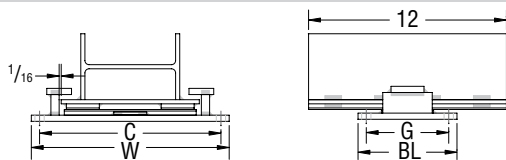

Type 4

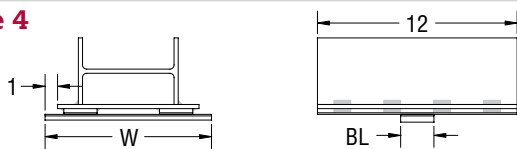

Type 4

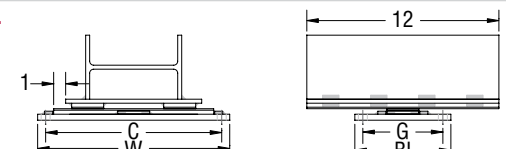

Type 5

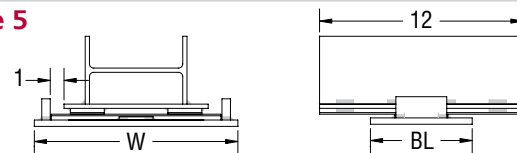

Type 5

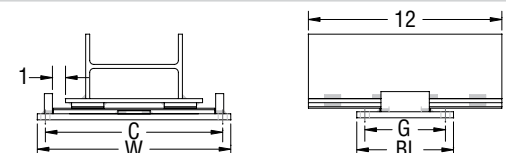

Notes:

- Types 1, 2, and 3 provide for longitudinal movement only.
- Types 4 and 5 provide for both longitudinal and transverse movement of piping.

"H" Section Only

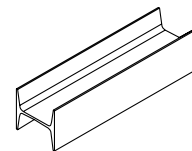

**Options
(for all types)**

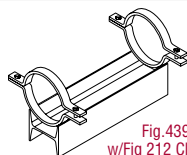

Fig. 439
w/ Fig 212 Clamps

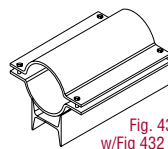

Fig. 439
w/ Fig 432 Clamp