

AS 100 PL, GR, PG, Other _____

SOLID 

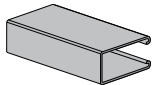
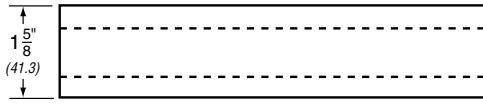

Wt./100 Ft: 313 Lbs

AS 100EH PL, GR, PG, Other _____

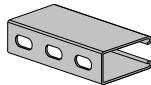
WITH ELONGATED HOLES 

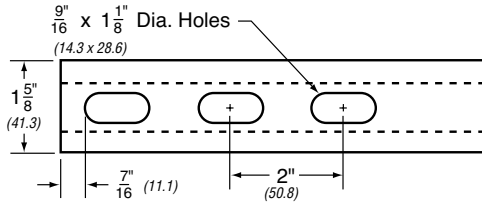

Wt./100 Ft: 300 Lbs

AS 100KO PL, GR, PG, Other _____

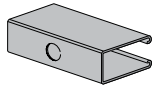
WITH KNOCK OUT 

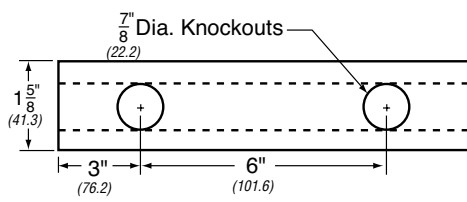

Wt./100 Ft: 313 Lbs

AS 100H PL, GR, PG, Other _____

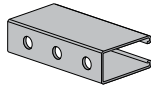
WITH HOLES 

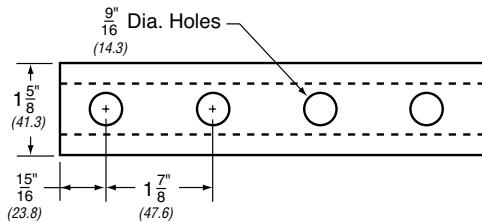

Wt./100 Ft: 308 Lbs

AS 100S PL, GR, PG, Other _____

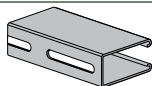
WITH LONG SLOTS 

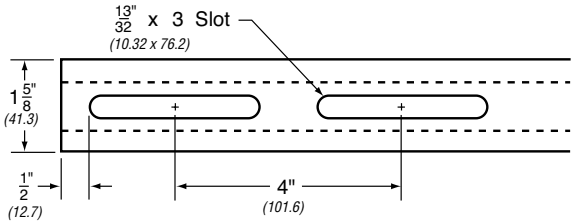

Wt./100 Ft: 298 Lbs

LEGEND:

GR: Powder Coated Supr-Green EG: Electro-Galvanized PG: Pre-Galvanized AL: Aluminum HG: Hot Dipped Galvanized PL: Plain SS: Stainless Steel ZTC: Zinc Trivalent Chromium
Stainless Steel (SS), Zinc Trivalent Chromium (ZTC) and Hot Dipped Galvanized (HG) are specialty finishes. Pricing is located in the Specialty Strut Section of the Anvil-Strut price book.

PROJECT INFORMATION		APPROVAL STAMP
Project:		<input type="checkbox"/> Approved
Address:		<input type="checkbox"/> Approved as noted
Contractor:		<input type="checkbox"/> Not approved
Engineer:		Remarks:
Submittal Date:		
Notes 1:		
Notes 2:		

AS 100

3 1/4" X 1 5/8" (82.6 x 41.3mm)
12 Gauge Channel • wt./100 ft. - 313#

Stocked in pre-galvanized, plain and powder coated Supr-green, in both 10 and 20 ft. lengths. Other materials, finishes and lengths are available upon request.

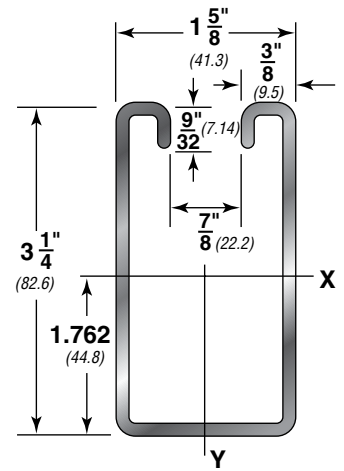
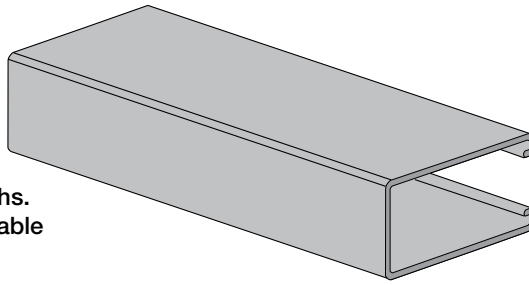

PROPERTIES OF SECTION

Catalog No.	Wt./Ft.		Area of Section		X-X Axis						Y-Y Axis					
	Lbs.	Kg	Sq. In.	Sq. CM	I in ⁴	I cm ⁴	S in ³	S cm ³	r in.	r cm	I in ⁴	I cm ⁴	S in ³	S cm ³	r in.	r cm
AS 100	3.13	4.7	0.887	5.723	1.100	45.785	0.633	10.373	1.114	2.830	0.431	17.940	0.530	8.685	0.697	1.770

I = Moment of Inertia S = Section Modulus r = Radius of Gyration

BEAM & COLUMN LOADS

Span or Unbraced Height	Static Beam Load (X-X Axis)						Max. Allowable Load at Slot Face	Column Loading Data					
	Max Allowable Uniform Load	Deflection at Uniform Load	Uniform Load at Deflection					Max. Column Load Applied at C.G.					
			Span/180 Deflection	Span/240 Deflection	Span/360 Deflection	Weight of Channel		k=.65	k=.80	k=1.0	k=1.2		
In	Lbs	In	Lbs	Lbs	Lbs	Lbs	Lbs	Lbs	Lbs	Lbs	Lbs	Lbs	Lbs
12	10,610	0.01	10,610	10,610	10,610	3.1	6,170	19,600	19,060	18,210	17,240		
18	7,070	0.02	7,070	7,070	7,070	4.7	5,950	18,320	17,240	15,630	13,920		
24	5,300	0.03	5,300	5,300	5,300	6.3	5,650	16,720	15,070	12,770	10,560		
30	4,240	0.05	4,240	4,240	4,240	7.8	5,270	14,920	12,770	10,030	7,640		
36	3,540	0.07	3,540	3,540	3,540	9.4	4,840	13,060	10,560	7,640	5,650		
42	3,030	0.09	3,030	3,030	3,030	11.0	4,360	11,230	8,560	5,910	4,450		
48	2,650	0.12	2,650	2,650	2,650	12.5	3,860	9,530	6,850	4,790	3,660		
60	2,120	0.18	2,120	2,120	1,920	15.7	3,100	6,680	4,790	3,450	2,710		
72	1,770	0.26	1,770	1,770	1,340	18.8	2,570	4,980	3,660	2,710	2,170		
84	1,520	0.36	1,520	1,470	980	21.9	2,200	3,950	2,960	2,240	1,820		
96	1,330	0.47	1,330	1,130	750	25.0	1,930	3,270	2,500	1,920	1,580		
108	1,180	0.60	1,180	890	590	28.2	1,730	2,800	2,170	1,690	1,390		
120	1,060	0.74	960	720	480	31.3	1,560	2,450	1,920	1,510	**		
144	880	1.06	670	500	330	37.6	1,320	1,980	1,580	**	**		
168	760	1.44	490	370	250	43.8	1,150	1,670	1,340	**	**		
180	710	1.65	430	320	210	47.0	**	1,550	**	**	**		
192	660	1.88	380	280	190	50.1	**	1,450	**	**	**		
216	590	2.38	300	220	150	56.3	**	**	**	**	**		
240	530	2.94	240	180	120	62.6	**	**	**	**	**		

Bearing Load may limit load
 ** Not recommended - KL/r exceeds 200

Notes

- The beam capacities shown above include the weight of the strut beam. The beam weight must be subtracted from these capacities to arrive at the net beam capacity.
- Allowable beam loads are based on a uniformly loaded, simply supported beam. For capacities of a beam loaded at midspan at a single point, multiply the beam capacity by 50% and deflection by 80%.

3. The above chart shows beam capacities for strut without holes. For strut with holes, multiply by the following:

- EH by 88%, S by 90%,
- H (% holes) by 88%, KO by 82% .

4. Refer to the Anvil-Strut Catalog for reduction factors for unbraced lengths

BEAM & COLUMN LOADS - METRIC

Span or Unbraced Height	Static Beam Load (X-X Axis)						Max. Allowable Load at Slot Face	Column Loading Data			
	Max Allowable Uniform Load	Deflection at Uniform Load	Uniform Load at Deflection					Max. Column Load Applied at C.G.			
			Span/180 Deflection	Span/240 Deflection	Span/360 Deflection	Weight of Channel		k=.65	k=.80	k=1.0	k=1.2
			mm	Kn	mm	Kn					
305	47.2	0.3	47.2	47.2	47.2	1.4	27.4	87.2	84.8	81.0	76.7
457	31.4	0.5	31.4	31.4	31.4	2.1	26.5	81.5	76.7	69.5	61.9
610	23.6	0.8	23.6	23.6	23.6	2.9	25.1	74.4	67.0	56.8	47.0
762	18.9	1.3	18.9	18.9	18.9	3.5	23.4	66.4	56.8	44.6	34.0
914	15.7	1.8	15.7	15.7	15.7	4.3	21.5	58.1	47.0	34.0	25.1
1,067	13.5	2.3	13.5	13.5	13.5	5.0	19.4	50.0	38.1	26.3	19.8
1,219	11.8	3.0	11.8	11.8	11.8	5.7	17.2	42.4	30.5	21.3	16.3
1,524	9.4	4.6	9.4	9.4	8.5	7.1	13.8	29.7	21.3	15.3	12.1
1,829	7.9	6.6	7.9	7.9	6.0	8.5	11.4	22.2	16.3	12.1	9.7
2,134	6.8	9.1	6.8	6.5	4.4	9.9	9.8	17.6	13.2	10.0	8.1
2,438	5.9	11.9	5.9	5.0	3.3	11.3	8.6	14.5	11.1	8.5	7.0
2,743	5.2	15.2	5.2	4.0	2.6	12.8	7.7	12.5	9.7	7.5	6.2
3,048	4.7	18.8	4.3	3.2	2.1	14.2	6.9	10.9	8.5	6.7	**
3,658	3.9	26.9	3.0	2.2	1.5	17.1	5.9	8.8	7.0	**	**
4,267	3.4	36.6	2.2	1.6	1.1	19.9	5.1	7.4	6.0	**	**
4,572	3.2	41.9	1.9	1.4	0.9	21.3	**	6.9	**	**	**
4,877	2.9	47.8	1.7	1.2	0.8	22.7	**	6.4	**	**	**
5,486	2.6	60.5	1.3	1.0	0.7	25.5	**	**	**	**	**
6,096	2.4	74.7	1.1	0.8	0.5	28.4	**	**	**	**	**

CHANNEL SPECIFICATIONS

Materials

CARBON STEEL

Channels are formed from high-quality, structural grade carbon steel which has been manufactured in accordance with ASTM A-1011-04-SS Grade 33 (hot rolled), or ASTM 366 (cold rolled), with mechanical properties of 33 ksi minimum yield and 52 ksi minimum tensile strength. The precision roll-forming process by which the channels are formed "cold works" the steel, thereby increasing its mechanical properties.

STAINLESS STEEL

Channels are formed from chromium-nickel stainless steel sheet manufactured in accordance with ASTM A-240 specification, offered in both AISI Type 304 and 316 material to provide protection in varying corrosive conditions.

ALUMINUM

Extruded aluminum channel is produced from 6063-T6 alloy, and fittings are produced from 5052-H32 alloy, both in accordance with ASTM B-221 specifications. Aluminum is suitable for use in various corrosive environments.

Finishes

PRE-GALVANIZED

Hot dip, mill galvanized coating produced through a process of continuously passing the steel through a bath of molten zinc. This process is performed in accordance with ASTM A-653. The thickness of the zinc coating conforms with ASTM G-90 which represents a coating thickness of .90 ounces of zinc per square foot. This coating is applied to the steel master coils prior to slitting and fabrication.

HOT DIP GALVANIZED - POST FABRICATION

The finished channel is completely immersed in a bath of molten zinc, resulting in the complete coating of all surfaces of the product, including edges and welds. Strut channels that are hot dip galvanized, have a total coating weight of 3.0 ounces of zinc per square foot in accordance with ASTM A-123 specification. This coating provides superior results in applications calling for prolonged outdoor exposure.

SUPR-GREEN POWDER COATING

Strut channels are coated after fabrication with polyester powder finish. This coating is applied using an electrostatic spray process, beginning with cleaning and phosphating, through a bonderite pretreatment process, and ending with oven curing. The resulting finish provides a high quality appearance and durability. Powder Coating is in accordance with ASTM B-117 (standard practice for operating salt spray (fog) apparatus) to 500 hours with less than 1/8" scribe creep.

ZINC TRIVALENT CHROMIUM

The finished channel undergoes a multi-step process consisting of electrogalvanizing, in accordance with ASTM B-633-85, followed by an application of zinc trivalent chromium, which provides the distinctive gold coloration of the finish. All surfaces are coated because the process is performed after fabrication.

PVC

A corrosive resistant PVC (polyvinyl chloride) coating is applied over the completed strut channel. The coating process consists of surface pretreatment, followed by preheating of the part, which is then passed through a fluidized bed of vinyl plastic powder. The powder melts onto the heated channel forming a smooth coating which undergoes a final heat curing.