

**ANVIL EPS**  
ENGINEERED PIPE SUPPORTS

No. PE-217-80  
Page 1 of 16  
Rev. 3  
Date 3-1-10

PREP. BY

FJB

APP.  
QAM

TITLE:

**INSTALLATION INSTRUCTIONS FOR  
ANVIL CONSTANT SUPPORT HANGERS**

**INSTALLATION INSTRUCTIONS  
FOR  
ANVIL CONSTANT SUPPORT HANGERS**

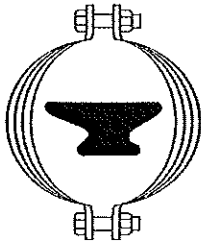

**ANVIL EPS**  
ENGINEERED PIPE SUPPORTS

No. PE-217-80  
Page 2 of 16  
Rev. 3  
Date 3-1-10

TITLE:

**INSTALLATION INSTRUCTIONS FOR  
ANVIL CONSTANT SUPPORT HANGERS**

**TABLE OF CONTENTS**

<b><u>Section</u></b>	<b><u>Title</u></b>	<b><u>Pages</u></b>
	Title Page	1
	Table of Contents	2
1.0	General Instructions	3-4
2.0	Constant Support Hangers	5-16

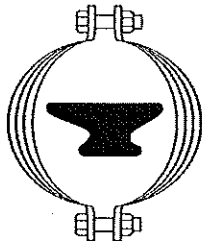

**ANVIL EPS**  
ENGINEERED PIPE SUPPORTS

No. PE-217-80  
Page 3 of 16  
Rev. 3  
Date 3-1-10

TITLE:

**INSTALLATION INSTRUCTIONS FOR  
ANVIL CONSTANT SUPPORT HANGERS**

**1.0 GENERAL**

- 1.1 Anvil Standard Supports are designed and engineered to support piping systems and piping system components. Standard Pipe Supports, either singly or in combination with other standard or special supports, are arranged according to the Hanger Assembly Drawing at each support point. During installation, each assembly must be installed in the location shown on the Hanger Assembly Drawing, within the tolerances listed. Any deviation outside the allowed tolerances shall be justified by the piping erector.

**CAUTION**

Use of pipe supports as erection devices or in any applications other than those for which they were designed can cause hanger failure resulting in property damage and personal injury. If in doubt concerning a particular application, contact your Anvil representative.

- 1.2 General support storage and installation instructions are found in MSS SP-89, Pipe Hangers and Supports, Manufacture and Installation (Manufacturer's Standardization Society of the Valves and Fittings Industry, Inc.), and Anvil Procedure PE-217-1.
- 1.3 Hanger assemblies are pre-assembled as far as practical, except that Constant Supports are shipped separate from the rest of the assembly. Individual cartons, skids, or loose material may weigh up to 2000# per item and may be handled by fork lift.
- 1.4 After final adjustments of the support are made, all threaded fasteners shall have thread engagements which meet the following requirements.
- a. For nuts, clevises, forged turnbuckles, threaded eye nuts, and other similar devices, the male thread shall fully engage the female thread.

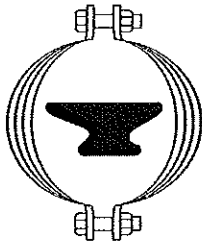

**ANVIL EPS**  
ENGINEERED PIPE SUPPORTS

No. PE-217-80  
Page 4 of 16  
Rev. 3  
Date 3-1-10

TITLE:

**INSTALLATION INSTRUCTIONS FOR  
ANVIL CONSTANT SUPPORT HANGERS**

- b. For load couplings and other devices having sight holes, the male thread must be visible in the sight hole. For three hole fabricated turnbuckles, the center hole should be clear.

For single hole rod couplings, both male threaded parts must be visible in the sight hole and they must be tightened against each other to prevent loosening.

**CAUTION**

Failure to have proper thread engagement before application of load can result in release of load and possible property damage or personal injury.

- 1.5 Jam nuts are supplied with many products to prevent threaded members from turning during erection, adjustment, and service. In order for the jam nuts to perform, they should be installed hand tight and then wrench tightened at least 1/8 turn. For course threads, where this requirement would be excessive, wrench tight is sufficient. The security of the jam nut should be verified after hydrostatic testing.

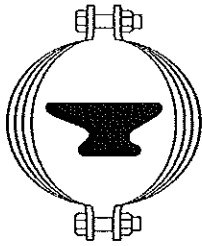

**ANVIL EPS**  
ENGINEERED PIPE SUPPORTS

No. PE-217-80  
Page 5 of 16  
Rev. 3  
Date 3-1-10

TITLE:

**INSTALLATION INSTRUCTIONS FOR  
ANVIL CONSTANT SUPPORT HANGERS**

**2.0 CONSTANT SUPPORTS**

- 2.1 This procedure covers all Constant Supports except the Fig. 81-H Type F which are covered in Instructions PE-217-81H.

Dimensions and data relative to the Constant Support Hanger may be found in the Anvil Pipe Hanger Catalog and the Anvil DRS/LCD Package.

Each Constant Support Hanger has a position scale marked H-M-L, indicating High, Mid and Low positions, respectively. Thus, if the travel indicator of the hanger were at the "H" position, the hanger would be at its maximum up or high position. Conversely, if the indicator were at "L", the hanger would be at its lowest position

There are two markers placed on the travel scale at the factory, a white corresponding to the cold position of the pipe, and red corresponding to the hot position of the pipe.

2.2 Installing the Constant Support Hanger:

- a. Refer to the hanger assembly drawing for piping and structural attachment locations, general arrangements, etc.
- b. Attach the structural attachment to the building structure as shown on the hanger assembly drawing and attach the Constant Support to the structural attachment.
- c. Connect the pipe attachment to the pipe when applicable. Attach the lower rod to the pipe attachment and hanger load coupling. Use of high temperature grease is recommended.

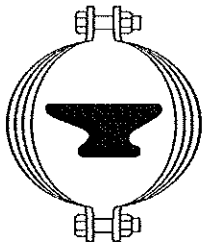

TITLE:

**INSTALLATION INSTRUCTIONS FOR  
ANVIL CONSTANT SUPPORT HANGERS**

- d. The hanger rod must be inclined no more than 5° from the vertical, unless otherwise specified on the Hanger Assembly Sketch.
- e. After all piping is installed, and after hydrostatic testing at ambient temperatures, all travel stops must be removed before system operation. Do not remove Travel Stop before the hanger is installed and the fully loaded and Hydrostatic Testing is completed.  
(See *NOTE* below)

**NOTE:**

Travel Stops must be removed prior to any testing or cleaning of the system done above ambient temperatures, and if this causes greater loads than the design loads, temporary supports must be provided.

**CAUTION**

Never insert anything other than travel stops in the travel indicator slot as severe personal injury can result.

- f. Constant Support Hangers are provided with travel stops that are painted red. Sizes 10 thru 110 are factory set to hold the hanger in the "cold" position and no further adjustments should be necessary. If, however, any of the Constant Support Hangers are not at the proper setting, turn the load coupling until the travel indicator is at the white, "Cold" marker. This procedure does not change the supporting force of the hanger, but assures the hangers capability of following the actual piping expansion and contraction. Sizes 1 thru 9 are factory set at the fully down position and will require the above adjustment.
- g. After performing the preceding step, any units that indicate an overload or underload condition to the extent that the position indicator comes up against the top or down against the bottom, the piping designer should be notified immediately, no substitution or modification should be made without specific instructions.

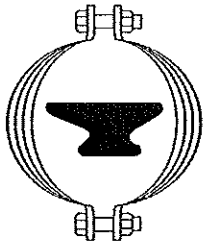

**ANVIL EPS**  
ENGINEERED PIPE SUPPORTS

No. PE-217-80  
Page 7 of 16  
Rev. 3  
Date 3-1-10

TITLE:

**INSTALLATION INSTRUCTIONS FOR  
ANVIL CONSTANT SUPPORT HANGERS**

2.3 TRAVEL STOP INSTALLATION & REMOVAL INSTRUCTIONS

2.3.1 Sizes 1 thru 9

The Travel Stop consists of a pin that passes through the frame. The hanger can be locked at either the fully up or fully down position. The Travel Stop is installed at the factory to hold the hanger at the fully down position. The Travel Stop is removed as follows:

- 1) Rotate the turnbuckle (to draw up the hanger rod) until the Travel Stop Pin is no longer bearing on the hole in the frame. (If this condition cannot be obtained, please refer to Para. 2.4 (a) and (b).
- 2) Remove the Travel Stop Pin and retain for future use.
- 3) Rotate the turnbuckle (to let out the hanger rod) until the Position Indicator is at the "Cold" position.

To re-engage the Travel Stop rotate the turnbuckle until the position indicator is in either the fully up or fully down position. Replace the Travel Stop Pin. Note that

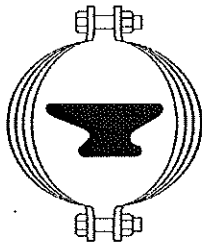

**ANVIL EPS**  
ENGINEERED PIPE SUPPORTS

No. PE-217-80  
Page 8 of 16  
Rev. 3  
Date 3-1-10

TITLE:

**INSTALLATION INSTRUCTIONS FOR  
ANVIL CONSTANT SUPPORT HANGERS**

2.3.2 Sizes 10 thru 18

There is a travel stop on each side of the constant support. Each Travel Stop consists of Plate "A", two hex head bolts "B" and washers "C". Plate "A" is a machined plate with a series of position indicator holes and (2) slotted holes for attachment to the hanger frame. The plate is attached to the hanger frame with two bolts. The combination of holes can lock the hanger at any position along the total travel range.

The travel stop is removed as follows:

- 1) Rotate the load coupling and/or turnbuckle until the position indicator is no longer bearing on the hole in the travel stop. (If this condition cannot be obtained, please refer to Para. 2.4 (a) and (b).
- 2) Remove bolts which secure the plate to the hanger frame.
- 3) Swing the plates to a position where they do not impair hanger operation or obstruct view of the travel scale and position indicator.
- 4) When the Travel Stop is not in use, it may be stored by hanging the Plate "A" from the lower Bolt "B" and securely fastening it to the hanger frame. The other Bolt may be stored using the threaded hole provided in frame.

To re-engage Travel Stop position plate "A" onto Travel Indicator, and replace and tighten Bolts "B". If the slotted attachment holes do not line up use the reverse side of Plate "A".

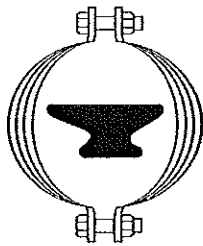

**ANVIL EPS**  
ENGINEERED PIPE SUPPORTS

No. PE-217-80  
Page 9 of 16  
Rev. 3  
Date 3-1-10

TITLE:

**INSTALLATION INSTRUCTIONS FOR  
ANVIL CONSTANT SUPPORT HANGERS**

2.3.3 Sizes 19 thru 110 \*

There is a Travel Stop on each side of the constant support. Each Travel Stop consists of two parts with matched serrations. Piece "A" is attached to the hanger frame with two or more hex head bolts "C". Piece "B" has a socketed piece that engages the position indicator and is fastened to Piece "A" with Fastener "D". The serrations can be engaged to lock the Constant Support Hanger at any position along the total travel range. The travel stop is removed as follows:

- 1) Rotate the load coupling and/or turnbuckle until the socketed piece which engages the position indicator is no longer a load bearing member. (If this condition cannot be obtained, please refer to Para. 2.4 (a) and (b).
- 2) To disengage Travel Stop, remove hex head bolts "C" which fasten Piece "A" to the frame. While it is not necessary to loosen Fastener "D", it is sometimes beneficial to do so in order to verify the proper tension on the rod.
- 3) Swing stops to a position where they do not impair hanger operation or obstruct view of the travel scale and position indicator.
- 4) When the Travel Stop is not in use, it may be stored by hanging Piece "A", "B", and "D" from one of the Bolts "C". Other Bolts may be stored in the threaded hole provided in frame for possible future use. Securely fasten stops to hanger frame and retain bolts.

To re-engage Travel Stop, loosen Fastener "D", position moveable Piece "B" onto Travel Indicator, and replace and tighten Bolts "C" and Fastener "D".

\* NOTE: See 2.3.4 for replacement travel stops for old style size 35-49.

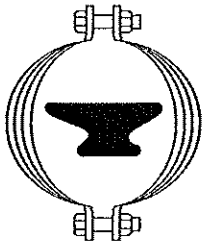

**ANVIL EPS**  
ENGINEERED PIPE SUPPORTS

No. PE-217-80  
Page 10 of 16  
Rev. 3  
Date 3-1-10

TITLE:

**INSTALLATION INSTRUCTIONS FOR  
ANVIL CONSTANT SUPPORT HANGERS**

2.3.4 Size 35 thru 49 Old Style Replacement

There is a Travel Stop on each side of the constant support. Each Travel Stop consists of two arms (one long – Piece “A” and one short – Piece “B”) and a socketed Piece “C” that engages the position indicator.

To Install:

- 1) Install Piece “C” over the indicator pin
- 2) Install Piece “A” over Piece “C” and fasten with Bolt “E” to one of the 2 tapped Travel Stop attachment holes.
- 3) Install Piece “B” over both Piece “A” and Piece “C” and fasten with Bolt “F” to the other tapped hole.
- 4) Install fastener Nut “D”.
- 5) Tighten the attachment Bolts “E” & “F” and Nut “D” snug tight.

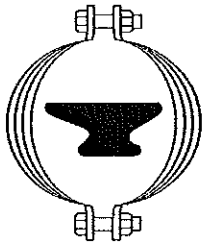

TITLE:

**INSTALLATION INSTRUCTIONS FOR  
ANVIL CONSTANT SUPPORT HANGERS**

2.4 Instructions for Load Adjustments

- a. If a change is desired in the supporting force of the hanger, field adjustment up to plus or minus 10% of the calibration load can be made in the field.

The percentage increase or decrease from the factory adjusted load should be carefully calibrated by an arrow die-stamped on the load scale plate.

All adjustments should be made from this reference point, with each division on the scale equal to 2% of the calibrated load (1% on Sizes 84-110).

The load adjustment is made by turning the load adjustment bolt.

- b. If, during or after installation of constant supports, the pipe cannot be held at the proper elevation with the position or travel indicator at the desired setting on the Position or Travel Scale, proceed as follows:
- 1) If the actual pipe load is greater than the supporting force of the constant supports,

Correct by - increasing the supporting force of the hanger by 2% by means of the load adjustment bolt and then adjusting the load coupling until the Position or Travel Indicator is at the proper setting and the pipe is at the required elevation. If the load adjustment is insufficient to achieve the desired results, repeat the above in increments of 2% until the pipe can be held at the proper elevation with the Travel Indicator at the desired setting.

Do not exceed a total of 10% adjustment without consulting your Anvil representative.

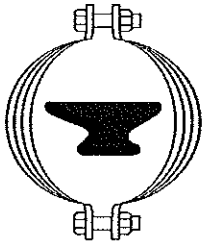

TITLE:

**INSTALLATION INSTRUCTIONS FOR  
ANVIL CONSTANT SUPPORT HANGERS**

- 2) If the actual pipe load is less than the supporting force of the constant supports,

Correct by - decreasing the supporting force of the hanger by 2% by means of the load adjustment bolt and then adjusting the load coupling until the Position or Travel Indicator is at the proper setting and the pipe at the required elevation. If the load adjustment is insufficient to achieve the desired results, repeat the above in increments of 2% until the pipe can be held at the proper elevation with the Travel Indicator at the desired setting. Do not exceed a total of 10% adjustment without consulting your Anvil representative.

If the desired results cannot be obtained with the available load adjustment, the weight of materials used in the hanger load calculations should be checked, new weight balance calculations performed and new hangers of a different size selected.

2.5 Inspection and Maintenance

- a. Each hanger should be inspected annually to verify its travel position relative to pipe condition, hot or cold. Adjustment of the travel indicator to the proper position on the travel scale is accomplished by turning the load coupling.
- b. No lubrication of moving parts is required.
- c. All dust, soot and foreign objects which may impair hanger operation shall be removed.

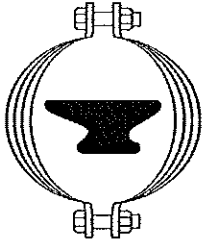

**ANVIL EPS**  
ENGINEERED PIPE SUPPORTS

No. PE-217-80  
Page 13 of 16  
Rev. 3  
Date 3-1-10

TITLE:

**INSTALLATION INSTRUCTIONS FOR  
ANVIL CONSTANT SUPPORT HANGERS**

**FIG. 81-H TRAVEL STOPS**  
**Sizes 1 thru 9**

TRAVEL STOP PIN

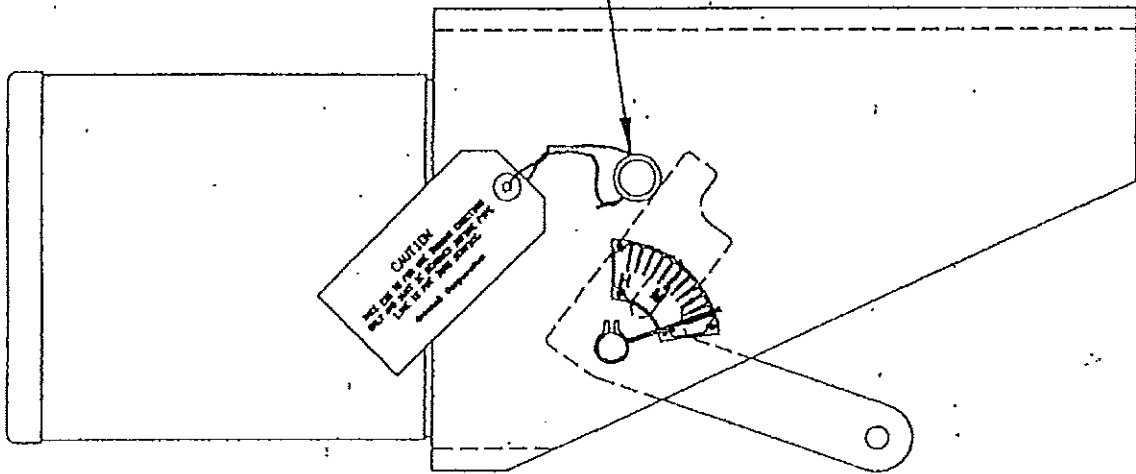

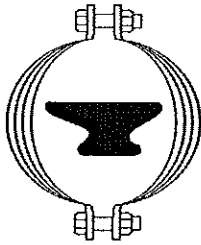

**ANVIL EPS**  
ENGINEERED PIPE SUPPORTS

No. PE-217-80  
Page 14 of 16  
Rev. 3  
Date 3-1-10

TITLE:

**INSTALLATION INSTRUCTIONS FOR  
ANVIL CONSTANT SUPPORT HANGERS**

**FIG. 80-V & 81-H TRAVEL STOPS**  
**SIZES 10 thru 18**

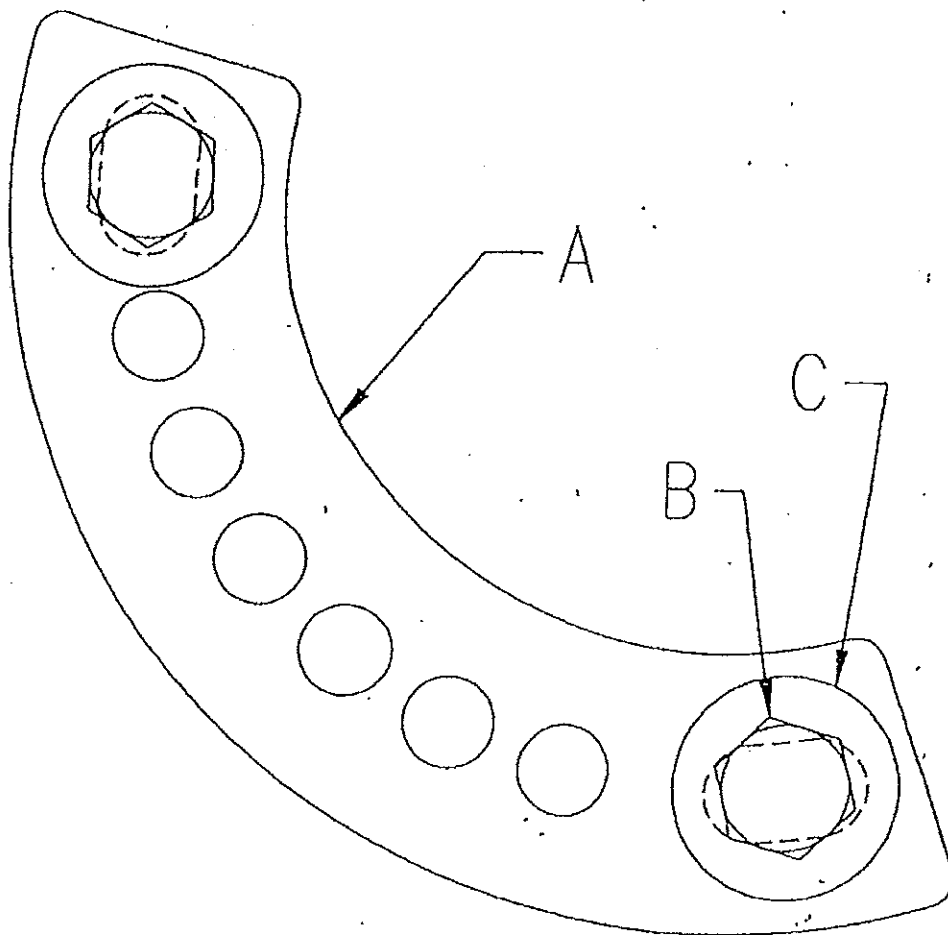

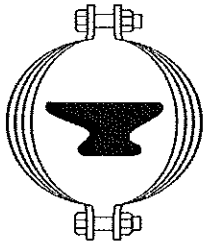

**ANVIL EPS**  
ENGINEERED PIPE SUPPORTS

No. PE-217-80  
Page 15 of 16  
Rev. 3  
Date 3-1-10

TITLE:

**INSTALLATION INSTRUCTIONS FOR  
ANVIL CONSTANT SUPPORT HANGERS**

**FIG. 80-V & 81-H TRAVEL STOPS**  
**SIZES 19 thru 110**

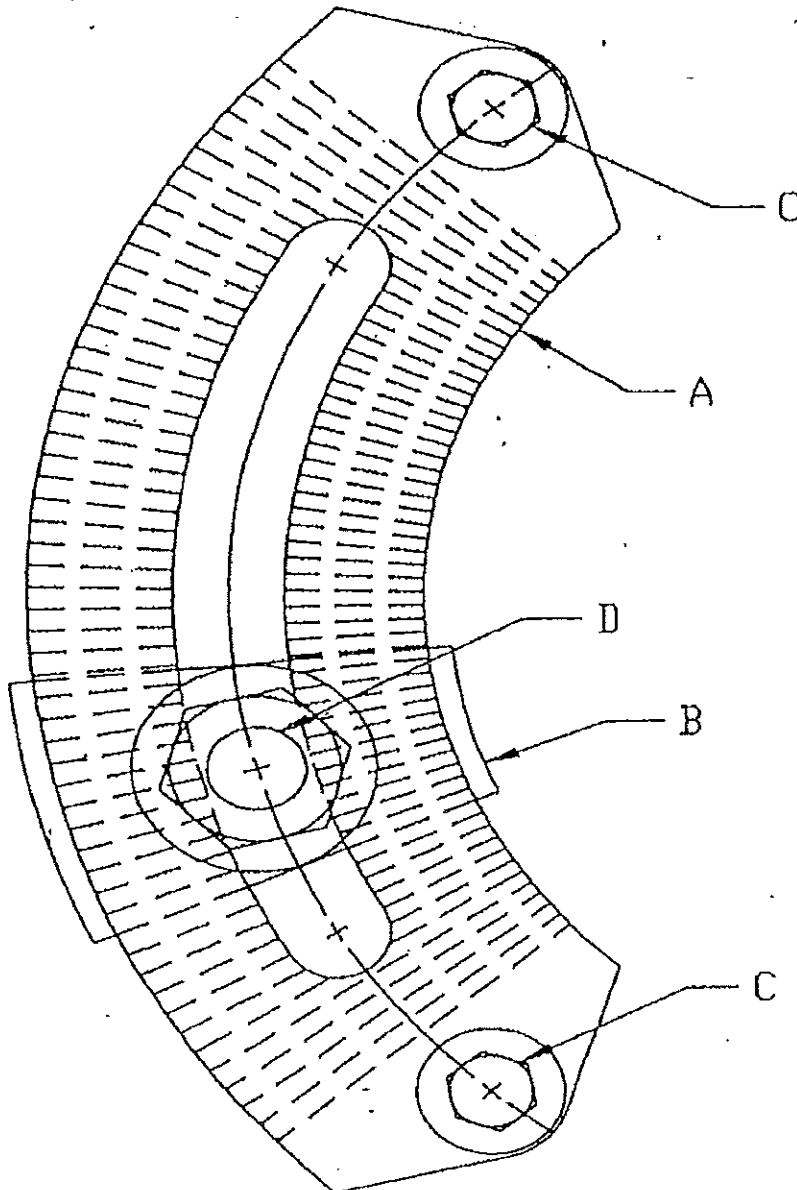

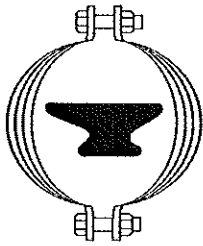

**ANVIL EPS**  
ENGINEERED PIPE SUPPORTS

No. PE-217-80  
Page 16 of 16  
Rev. 3  
Date 3-1-10

TITLE:

**INSTALLATION INSTRUCTIONS FOR  
ANVIL CONSTANT SUPPORT HANGERS**

**FIG. 80-V & 81-H REPLACEMENT TRAVEL STOPS**  
**SIZES 35-49 OLD STYLE**

