

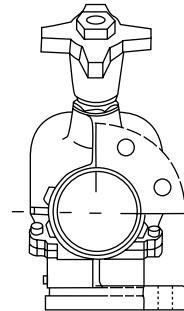

Grooved/Flanged Balancing Valves

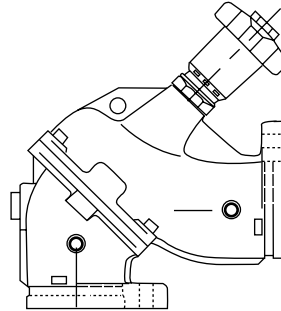
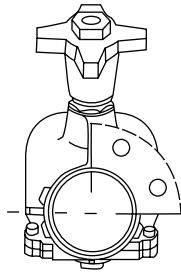
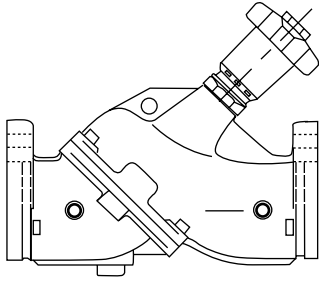

**Model GBV-G
Straight Design**

**Model GBV-A
Angle Design**

INDEX

1.0	Installation of Valve	2
2.0	Installation of Flange Adapters	3
3.0	Conversion - Straight to Angle	4
4.0	Operation	4
5.0	Memory Setting (2-1/2" - 6")	4-5
6.0	Memory Setting (8" and larger)	5
7.0	Repositioning Handwheel (2-1/2" - 6")	5
8.0	Repositioning Handwheel (8" and larger)	5
9.0	Repacking of Valve (2-1/2" - 6")	5-6
10.0	Repacking of Valve (8" and larger)	6
11.0	Flow Curves (Angle Design)	7
12.0	Flow Curves (Straight Design)	8

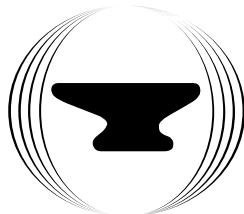

ANVIL™
INTERNATIONAL, INC.

CALIFORNIA: Fullerton 92831, 1600 E. Orangethorpe, Phone: (714) 773-1166, Fax: (714) 879-2319
 ILLINOIS: University Park 60466, 750 Central Ave., Phone: (708) 534-1414, Fax: (708) 534-5334
 GEORGIA: Norcross 30071, 6344 Cash Court, Phone: (770) 662-8177, Fax: (770) 662-0284
 PENNSYLVANIA: Bristol 19007, 2530 Pearl Buck Road, Phone: (215) 672-3444, Fax: (215) 672-4406
 TEXAS: Grand Prairie 75050, 1313 Avenue R, Phone: (972) 343-9206, Fax: (972) 641-8946

www.anvilintl.com

1.0 INSTALLATION

- 1.1 To ensure accuracy of measurement, the GBV should be located at least five pipe diameters downstream from any fitting, and at least ten pipe diameters downstream from a pump. Two pipe diameters downstream from the GBV should be free of any fitting (as illustrated in Figure 1).

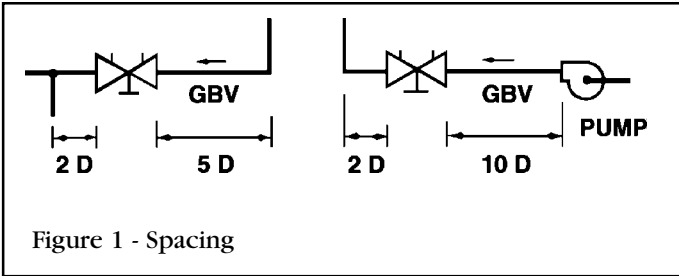

- 1.2 GBV valves must be installed with flow in the direction of the arrow of the valve body. Easy access to the probe metering ports (P.M.P.'s) and handwheel must be provided.
- 1.3 GBV valves can be installed in horizontal or vertical piping. The metering ports should never be installed below the pipe (pointing down), as this will allow system sediment to accumulate in the ports. (Illustrated below for horizontal piping in Figure 2.)

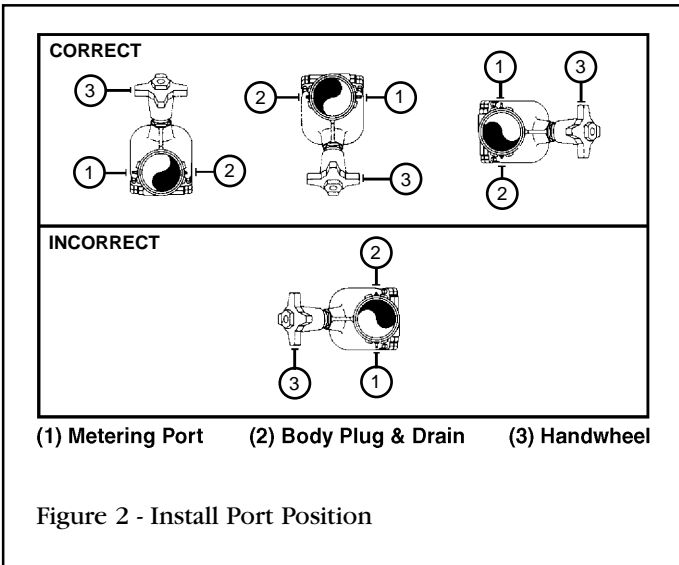

- 1.4 GBV angle-style valves are designed to replace piping elbows.
- 1.5 Metering ports and body plugs may be interchanged for improved accessibility.

2.0 FLANGE ADAPTERS

2.1 The Fig. 7012 Gruvlok Flange Adapter can be used with the GBV Balancing Valves. Installation is similar to the installation of the Figure 7012 with grooved pipe.



2.2 Loosen the nut on the latch bolt to the end of the bolt thread. (It is not necessary to remove the nut from the latch bolt.) Swing the latch bolt out of the slot. Open the Gruvlok Flange and place it around the grooved tube with the key section fitting into the groove. The flange gasket cavity must face the tube end.



2.3 Swing the latch bolt back into the slotted hole. Tighten the nut until the flange halves make solid contact.



2.4 Check the gasket grade to verify that it is properly suited for the intended service. Lubricate the entire surface of the gasket and the flange gasket cavity using Gruvlok lubricant. Position the Gruvlok Flange Gasket around the tube end and press the gasket into the cavity between the tube O.D. and the flange recess. The gasket must be properly positioned as shown in Step 2.5. Be careful that foreign particles do not adhere to lubricated surfaces.



2.5 The correct positioning and relationship of all components comprising a Gruvlok Flange joint. The Fig. 7012 Gruvlok Flange gasket must be inserted so that the sealing lips face toward the tube end and the mating flange face and away from the Gruvlok Flange itself.

NOTE: Design of the Gruvlok Flange provides sealing only with the special Gruvlok Flange gasket. Only Gruvlok Flange gaskets may be used with Fig. 7012 Gruvlok Flanges.

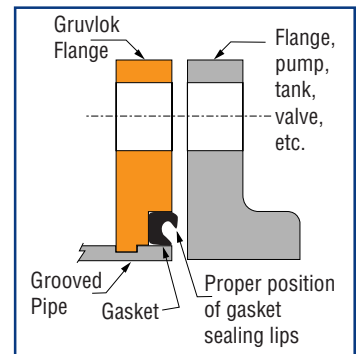

2.6 Align the Gruvlok Flange bolt holes with the mating flange bolt holes. Insert a standard bolt or stud through the bolt hole, and thread a nut on hand tight. Insert the next bolt or stud opposite the first and again thread the nut on hand tight. Continue this procedure until all holes have been fitted.



NOTE: Take care to assure that the gasket lip is not bent backwards or pinched between the two flanges.

2.7 Tighten the nuts evenly so that the flange faces remain parallel and make firm even contact around the entire flange. Torque all bolts to required flange joint torque levels.



3.0 CONVERSION (Straight to Angle)

- 3.1 Open the valve one complete turn.
- 3.2 Remove the body bolts from the valve body.
- 3.3 Rotate one-half of the valve body, 180°, making sure the seat and the “O” ring stay in position and does not get nicked or cut.
- 3.4 Replace the body bolts and tighten evenly.

4.0 Operation

- 4.1 The valve operates from closed (Figure 4) to partially open (Figure 5) to fully open (Figure 6) by a counter-clockwise rotation of the orange handwheel, using five 360° turns for the 2-1/2” and 3” valves, six turns for the 4”, 5” and 6” valves, 12 turns for the 8” and 10” valves and 14 turns for the 12” valve. The position of the valve is indicated by two scales.

Inner Scale (Figure 6) - This sleeve has a vertical arrowed scale which indicates the number of full turns the valve has been opened.

Outer Scale (Figure 6) - This scale is a micrometer-type scale marked 0-9 at the tapered base of the orange handwheel. Each gives 1/10th indications for each 360° turn of opening against the indicator line of the Inner Scale.

Figure 4 – With no arrows visible, the Inner Scale set at 0 on the indicator line aligned with the 0 on the Outer Scale; the valve is closed.

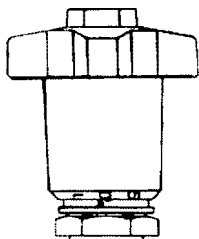

Figure 5 - Shows a valve setting of 2.0, indicating that the valve is partially open.

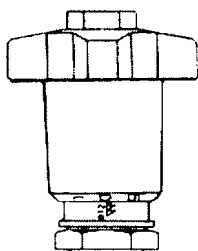

Figure 6 - With all arrows visible, the Inner Scale, set at 6 and the indicator line aligned with Outer Scale 0; the valve setting is 6.0 and the valve is fully open.



Connect meter quick-disconnect hoses to metering ports as follows:

- Remove protective cap from metering ports
 - Insert and lock the meter probe into the metering ports
- 4.2 The hose with the orange fitting upstream; the hose with the blue fitting, downstream.
 - 4.3 **CAUTION:** The probe should not be left inserted into the fitting for prolonged periods of time; overnight, etc., as leakage of the P.M.P. may occur when the probe is removed.

The locking nut on the probe is designed to hold it in the P.M.P. when taking readings in systems having a high working pressure. As sealing is accomplished internally on the probe stem, it is only necessary to tighten the locking nut finger-tight. Over-tightening may cause damage to the P.M.P. or locking nut threads.

- 4.4 Safety glasses should be used.
- 4.5 Before taking a flow measurement reading, set the valve to its fully open (4.0) or at a preset position. Read the pressure drop across the valve with a pressure differential meter. Determine GPM flow by use of valve Cv curve on pages 7 and 8.

5.0 Memory Setting (Figure 7) 2½" - 6" Valves

- 5.1 After the valve has been adjusted to its balance set point and without moving the handwheel, remove the retaining bolt from the end of the handwheel using a 1/4" Allen wrench.
- 5.2 Carefully remove the handwheel and turn indicator sleeve assembly, leaving the valve at its balance set point.
- 5.3 Turn the plastic memory stop (clockwise) down until it stops. Finger-tight pressure is sufficient. **DO-NOT-OVERTIGHTEN.**
- 5.4 Holding the memory stops in position, turn the lock collar (clockwise) down until it stops against the valve bonnet. The memory has now been set.
- 5.5 With the handwheel/turn indicator sleeve assembly still at its balance set point indication, reinstall them on the valve stem and hold in place with the 1/4" retaining bolt.

CAUTION: Care must be taken not to rotate the valve stem or change the handwheel/indicator setting while setting the memory.

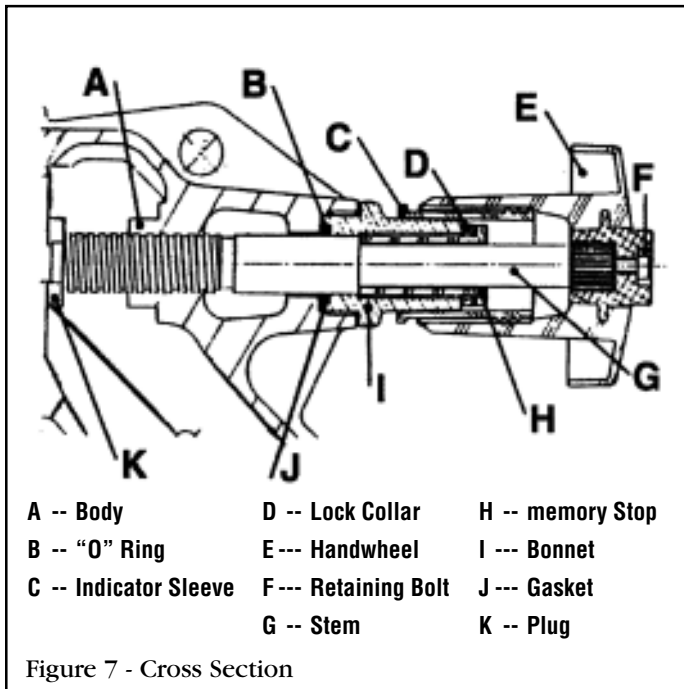

Figure 7 - Cross Section

6.0 MEMORY-SETTING (Figure 7) 8" Valves and Larger

- 6.1 After the valve has been set to the correct balance point, record the setting. Without turning the handwheel, remove the retaining bolt from the end of the handwheel.

- 6.2 Carefully remove the handwheel. Slight tapping with a mallet may be required but do not change the valve stem position.
- 6.3 Turn the brass memory lock ring until the aluminum memory ring stop contacts the step on the valve stem. **DO NOT OVERTIGHTEN.** Finger-tight pressure is sufficient.
- 6.4 Reinstall the handwheel in the correct orientation so that the original setting is indicated and secure with the retaining bolt.

7.0 REPOSITIONING HANDWHEEL 2½" - 6" Valves

- 7.1 The handwheel can be removed and repositioned in any of six positions around the stem.
 - a) Close valve fully.
 - b) Remove handwheel retaining bolt.
 - c) Remove handwheel and turn indicator sleeve by grasping the handwheel and pulling away from the valve body along the stem.
 - d) Select a new position for easy reading and, with the sleeve and handwheel held together in the closed position (0.0), push them back over the bonnet head and valve stem.
 - e) Replace handwheel retaining bolt.
 - f) Open valve.
- 7.2 If handwheel is removed for any reason, it is important to first close the valve, and then replace the handwheel per 7.1d) and 7.1e), above.

8.0 REPOSITIONING HANDWHEEL 8" Valves and Larger

- 8.1 The handwheel can be removed and repositioned in any of six (6) positions around the stem.
 - a) Close valve fully.
 - b) Remove handwheel retaining bolt
 - c) Remove handwheel by grasping handwheel and pulling away from the valve body along the stem. Slight tapping with a mallet may be required.
 - d) Select a new position for easy reading of the scale and reinstall the handwheel with the "0" mark located at the bottom pointed in this direction. Secure with the retaining bolt.
 - e) Loosen the scale retaining ring and rotate the turn indicator scale to align with the "0" on the handwheel. Tighten the scale retaining ring by hand. **DO NOT OVERTIGHTEN.**
 - f) Open the valve.

9.0 REPACKING GBV UNDER FULL SYSTEM PRESSURE 2½" - 6" Valves

- 9.1 Open valve fully to its memory setting and, on a piece of paper, record the valve setting.
- 9.2 Remove the handwheel/indicator sleeve assembly as per 5.1 and 5.2.
- 9.3 Loosen the lockcollar by turning it counter-clockwise until it seats against the top of the memory stop.
- 9.4 Remove the memory stop/lockcollar assembly by turning the plastic memory stop counter-clockwise.
- 9.5 Using the handwheel WITH THE INDICATOR SLEEVE REMOVED, turn the valve stem counter-clockwise until the valve is fully open and will not turn any further (45 ft. lbs.). A step on the valve plug has now been back-seated against the upper portion of the valve body (metal-to-metal).
- 9.6 The valve bonnet may now be removed. There may be slight leakage, as the metal-to-metal backseating does not provide a drip-tight seal.
- 9.7 Clean exposed portion of valve stem (Do not scratch).
- 9.8 Remove and replace the "O" ring and gasket.
- 9.9 Install the valve bonnet.
- 9.10 Replace memory stop/lockcollar assembly into the valve bonnet.
- 9.11 Close the valve fully by turning the stem in a clockwise direction. Tightening valve bonnet is necessary to stop any leaks.
- 9.12 Replace handwheel/indicator sleeve assembly per 7.1 d) and e), previous page.
- 9.13 Open valve to balance set point as recorded in 9.1.
- 9.14 Reset memory per 5.0

10.0 REPACKING GBV UNDER FULL SYSTEM PRESSURE -- 8" Valves and Larger

- 10.1 Open the valve fully to its memory setting and, on a piece of paper, record the valve setting.
- 10.2 Remove handwheel as per 6.1 and 6.2.
- 10.3 Loosen scale retaining ring and remove turn indicator assembly. It is not necessary to change the memory set point.
- 10.4 Using the handwheel, turn the stem counterclockwise until it stops (50 ft.lbs.). A step on the stem has now been back-seated against the upper portion of the valve body.
- 10.5 The valve bonnet may now be removed. There may be slight leakage as the back seat does not provide a drip-tight seal.
- 10.6 Clean exposed portion of valve stem.
(DO NOT SCRATCH).
- 10.7 Remove and replace the "O" ring and gasket.
- 10.8 Install the valve bonnet. Torque to 70 ft. lbs.
- 10.9 Close valve fully.
- 10.10 Reinstall turn indicator assembly. Scale retaining ring should be hand-tight. **DO NOT OVERTIGHTEN**.
- 10.11 Reinstall handwheel and secure with retaining bolt.
- 10.12 Open valve to balance set point as recorded.

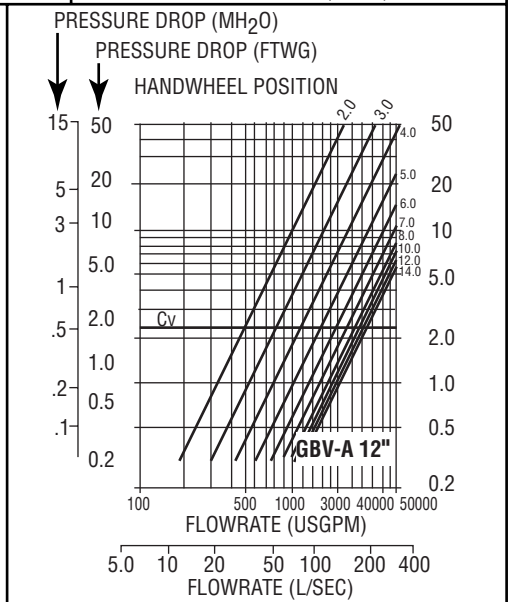
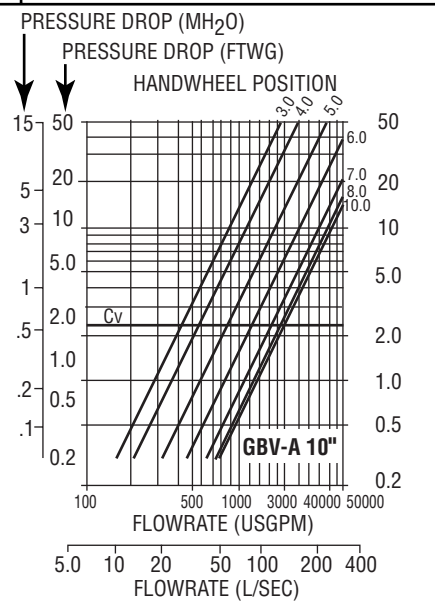
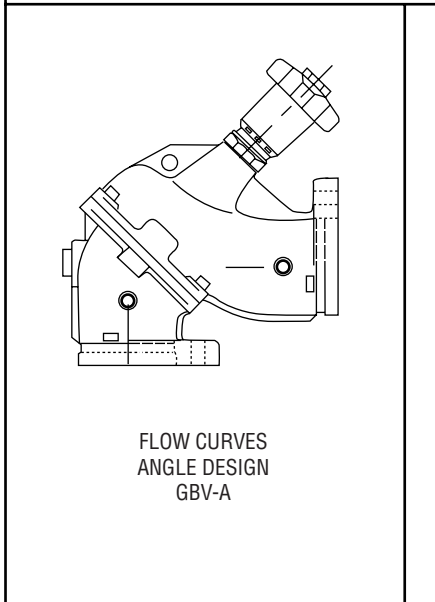
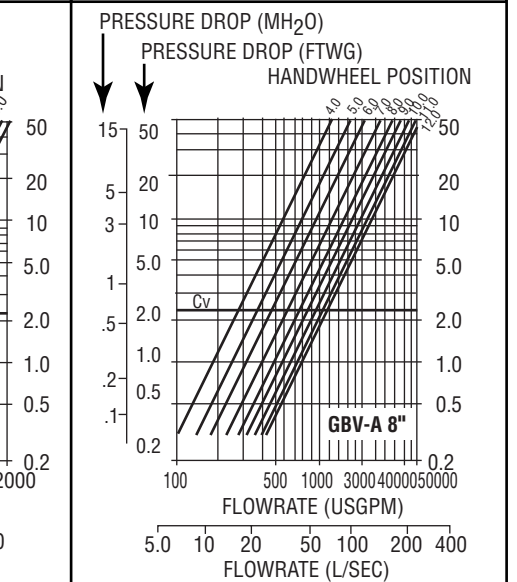
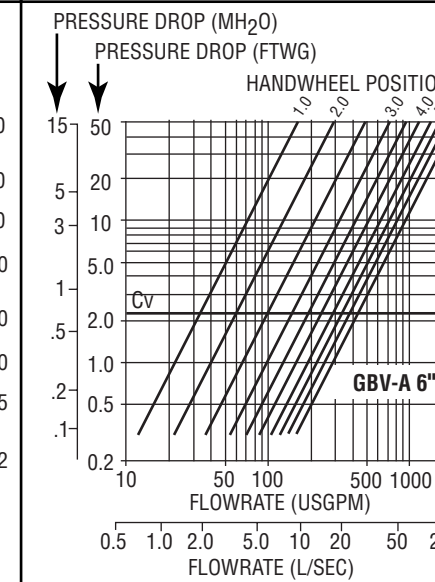
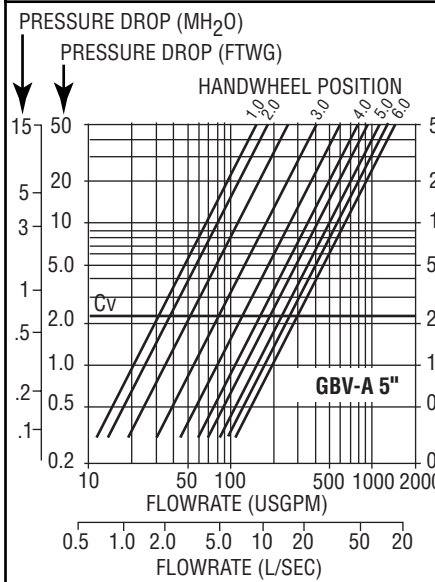
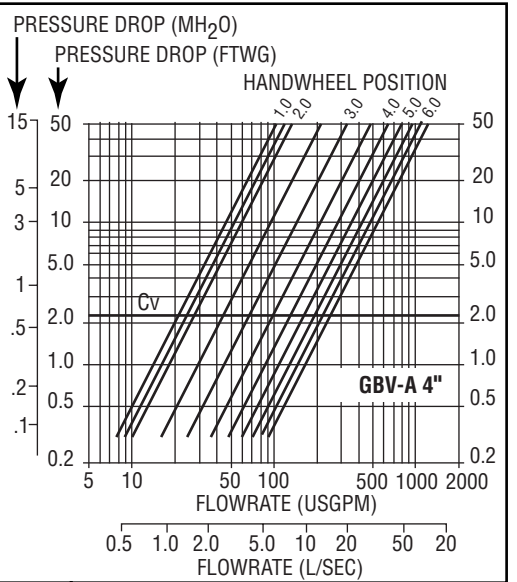
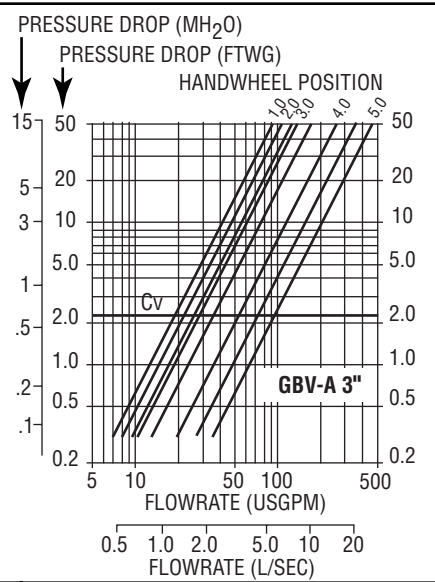
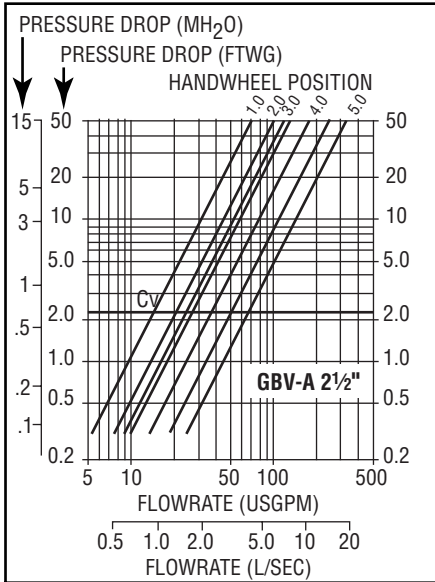

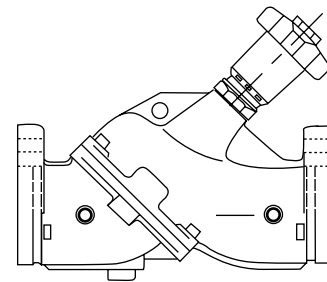
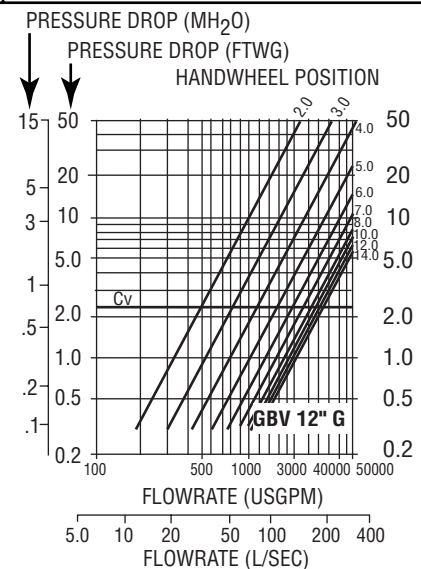
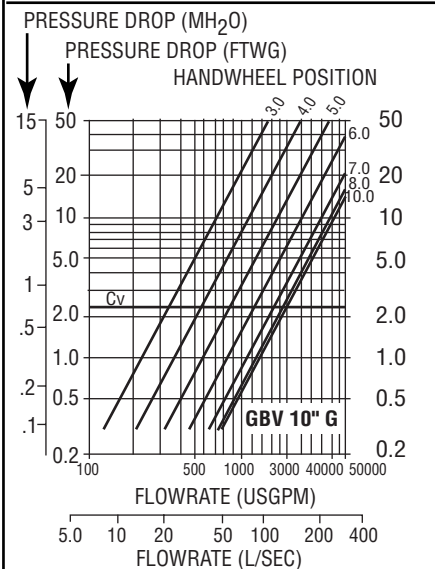
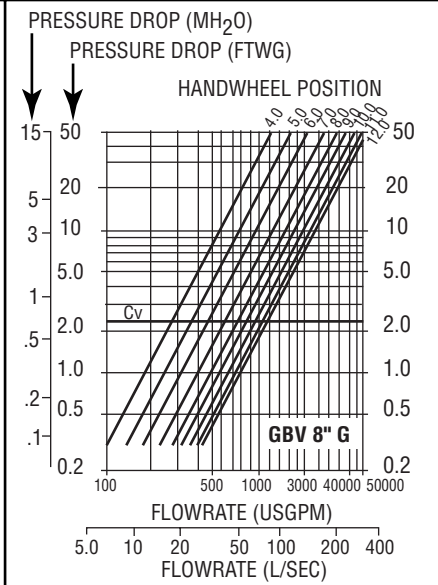
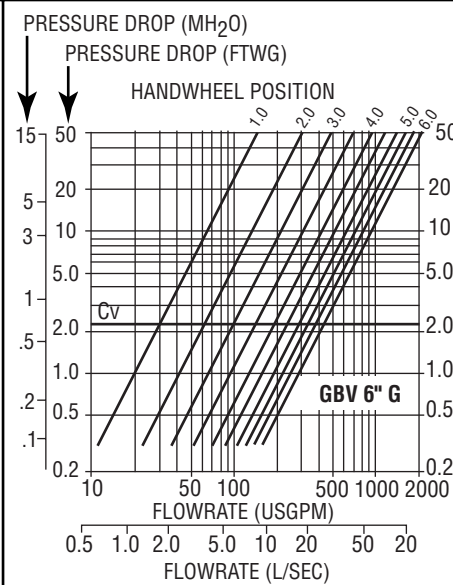
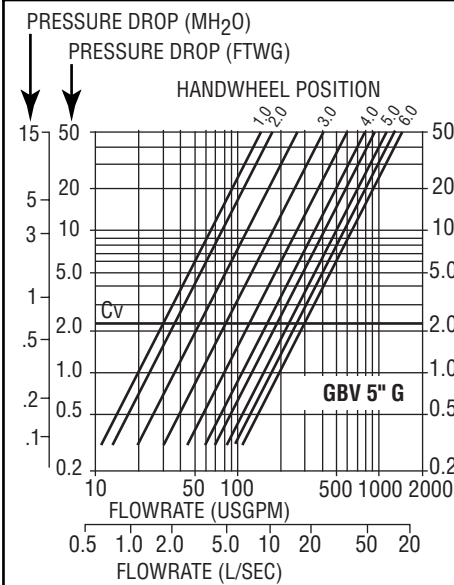
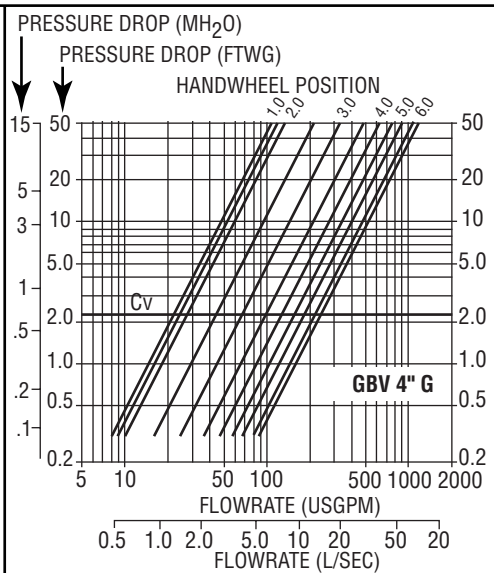
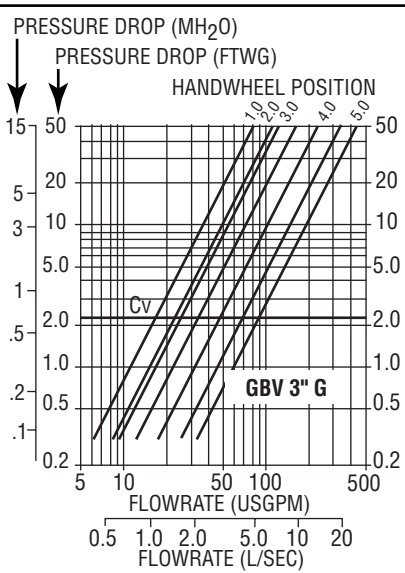
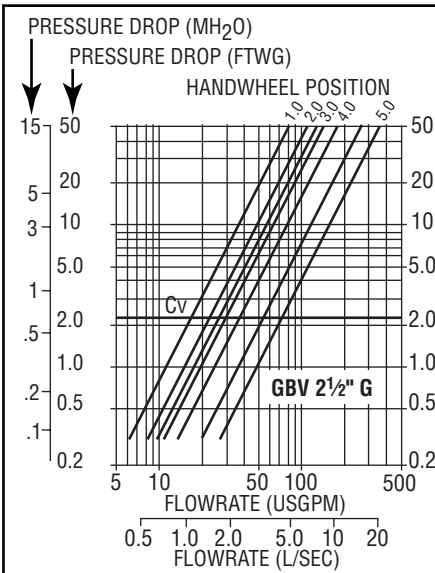

STRAIGHT CURVES
ANGLE DESIGN
GBV-G