

INSTALLATION AND OPERATING INSTRUCTIONS

Circuit Balancing Valves (Solder), Five Turn GBV-S



TYPICAL APPLICATIONS:

Anvil circuit balancing valves are most often used in hydronic heating and cooling installations, using a recirculating liquid as the heat transfer medium. Suitable liquids include water, glycol-water mixtures (both ethylene and propylene glycols), and brine. For applications or liquids other than these, please call Anvil Technical Support for recommendation of suitability of these valves in the target application.

MODEL GBV-S TECHNICAL DATA

Connection	Solder Joint
Maximum Working Pressure	300 psi / 20 bar (PN20)
Operating Temperature Range	300°F (150°C)

MATERIALS OF CONSTRUCTION

Body, Bonnet	Brass alloy CW617
Stem and Disk	Brass alloy B16
Elastomers	EPDM
Handwheel	Reinforced Nylon; ABS

FLOW RATE RANGES

VALVE SIZE	MIN. FLOW	MAX. FLOW
1/2" Low Flow	0.26 (0.016)	2.2 (0.14)
3/4" Low Flow	0.40 (0.025)	3.4 (0.21)
1/2"	1.4 (0.086)	10.4 (0.66)
3/4"	2.1 (0.13)	13.5 (0.85)
1"	5.2 (0.33)	20.2 (1.28)
1 1/4"	8.2 (0.51)	35.5 (2.24)
1 1/2"	8.1 (0.51)	48.9 (3.09)
2"	14.0 (0.88)	83.3 (5.25)

NOTE: Flow in USgpm (L/s)

MAXIMUM OPERATING PARAMETERS

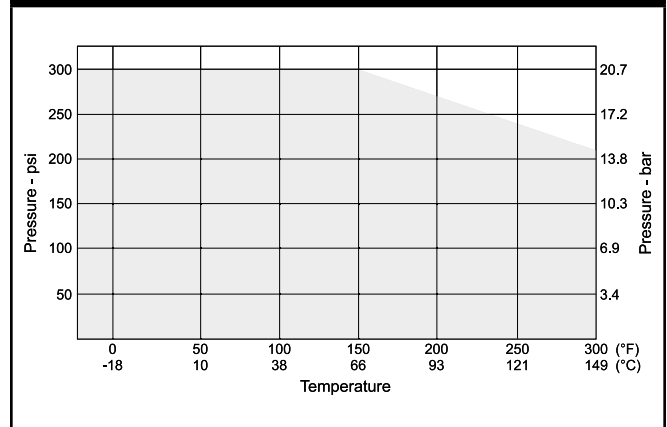

Circuit Balancing Valves (Solder), Five Turn GBV-S

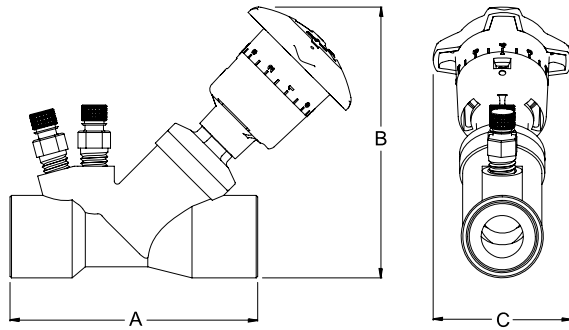

MODEL: GBV-S 1/2" - 2"					
DIMENSIONS & WEIGHTS					
Model	Pipe Size	A	B	C	Weight
GBV050VS	1/2"	3.19 (81)	4.56 (116)	2.76 (70)	1.05 (0.48)
GBV075VS	3/4"	3.64 (93)	4.65 (118)	2.76 (70)	1.09 (0.49)
GBV100VS	1"	4.26 (108)	4.95 (126)	2.76 (70)	1.68 (0.76)
GBV125VS	1 1/4"	4.94 (125)	5.40 (137)	2.76 (70)	2.26 (1.03)
GBV150VS	1 1/2"	5.67 (144)	5.60 (142)	2.76 (70)	3.22 (1.46)
GBV200VS	2"	7.03 (179)	6.36 (162)	2.76 (70)	5.40 (2.45)

NOTE: All dimensions are in inches (mm) and weights in lbs (kg).

INSTALLATION:

1. Clean the system piping of debris (pipe scale, rust, welding slag) and other contaminants. As with any water system it is important to make provisions to keep the system clean. For optimum operation, air entrapment in the fluid must be removed.
2. The operation of the valve is dependent on the fluid characteristics such as specific gravity and viscosity, which vary with the fluid temperature. For installations using fluids other than 100% water, flow rates must be corrected for the changes created by the fluid medium. See www.anvilintl.com for appropriate correction factors, or call your local Anvil representative.
3. To ensure accuracy of measurement Circuit Balancing Valves (GBV's) should be located at least five pipe diameters downstream from any fitting and at least ten pipe diameters downstream from a pump (as illustrated in Fig. 1).

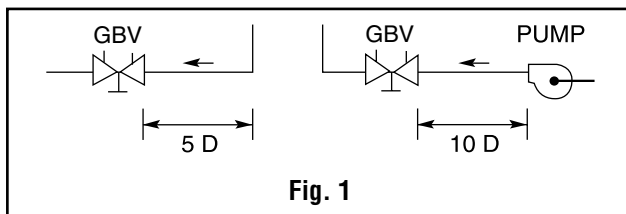

Fig. 1

4. All GBV's are marked with an arrow on the valve body to indicate direction of flow. The arrow must point in the direction of flow for proper operation.
5. GBV's may be installed in horizontal or vertical piping (as illustrated in Fig. 2). Provisions must be made for easy access to the probe metering ports (PMP's), reading scale, and memory stop.

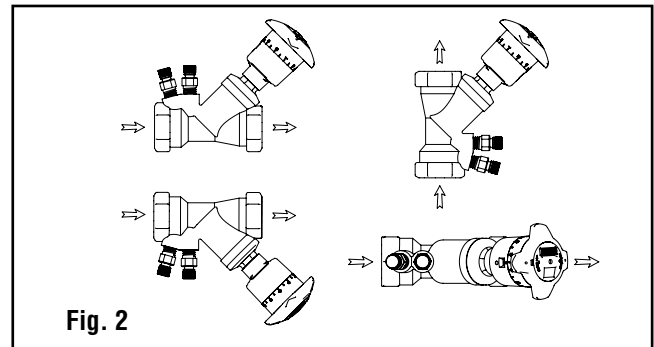

Fig. 2

SWEAT (SOLDER) CONNECTIONS:

6. GBV-S models are supplied with sweat style connections. Caution should be used when sweat style connection valves are installed to prevent overheating the valve.
7. Solder the valve body in line using 95/5 (95% tin, 5% antimony) type solder or equal. Always follow local plumbing codes for installation best practices.

CAUTION:

Before soldering, ensure the valve is opened at least one full turn to avoid damage to the sealing O-ring due to overheating. Anvil recommends that the GBV be protected during installation by wrapping a damp rag around the handle / bonnet assembly prior to soldering the valve into the line.

OPERATION:

8. Valves are circuit balancing valves that are selected to deliver the correct flow in a piping circuit based on line size and design flow rate.
9. To set the system flow, adjust the handwheel position until the differential pressure reading across the venturi corresponds to the required GPM.
10. The valve operates from fully open to closed by a clockwise rotation of the orange handwheel using five 360° turns. Two indicators describe the position of the valve: the handwheel turns dial and the micrometer scale.

• "Handwheel Turns" Dial:

This dial is printed on the outer surface of a gearing mechanism located inside the lower half of the handle assembly (Fig. 6). Each complete 360° revolution of the handwheel is visible through a display window and is scaled 0 - 5 to indicate the valve position in terms of the number of full turns. (Fig. 3)

• Micrometer Scale:

This scale is marked 0 - 9 and is located on the upper half of the handle assembly. Each mark represents 1/10th of a full, 360° turn of opening when lined up with an arrowhead symbol, located above the handwheel turns display window. (Fig. 3)

Fig. 3: GBV setting of 0.0 indicates that the valve is closed. Both the handwheel turns dial and the micrometer scale indicate a valve position reading of 0.

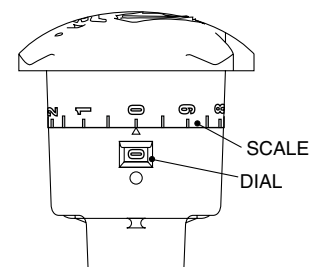

Circuit Balancing Valves (Solder), Five Turn GBV-S



11. The valve is considered “zeroed” when fully closed hand tight. The “0” on the micrometer scale should be within one half of $\frac{1}{10}$ th of a turn of the arrowhead symbol when the valve is closed hand tight. **DO NOT USE A WRENCH ON THESE VALVES – THEY SHOULD BE OPENED AND CLOSED HAND-TIGHT ONLY!**

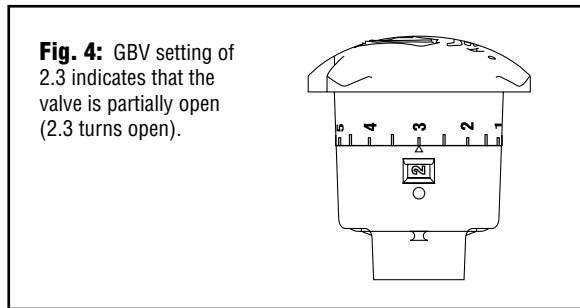

Fig. 4: GBV setting of 2.3 indicates that the valve is partially open (2.3 turns open).

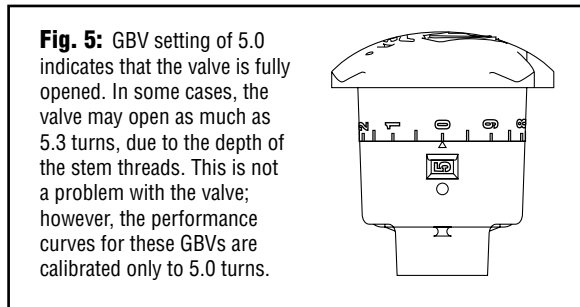
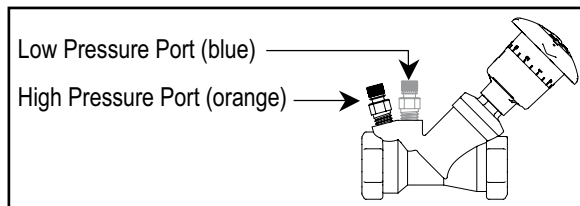

Fig. 5: GBV setting of 5.0 indicates that the valve is fully opened. In some cases, the valve may open as much as 5.3 turns, due to the depth of the stem threads. This is not a problem with the valve; however, the performance curves for these GBVs are calibrated only to 5.0 turns.

CAUTION:

Hot water leakage can occur from metering ports (P.M.P.'s) during probe insertion and hookup of metering device. Wear protective eyewear and clothing to prevent personal injury when measuring pressure.



12. Connect pressure measuring device to the GBV metering ports as follows:
- Remove protective cap from metering ports ($\frac{1}{4}$ " NPT connection).
 - Insert the meter probe into the metering ports. The hose with orange fitting, up stream; the hose with blue fitting downstream.

CAUTION:

When inserting probe, do not bend, as this will cause permanent damage to the probe, adversely affecting the pressure measurement. Do not use any lubrication on the probes when inserting them. If necessary, simply wet the probes with clean water.

The probe should not be left inserted into the fitting for prolonged periods of time, overnight, etc., as leakage of the P.M.P. may occur when the probe is removed.

The locking nut on the probe is designed to hold it in the P.M.P. when taking readings. As sealing is accomplished internally on the probe stem, it is only necessary to tighten the locking nut FINGER-TIGHT. Over-tightening may cause damage to the P.M.P. or locking nut threads.

13. Before taking a measurement reading, set the valve to its fully open position (5.0) or at a preset position. Read the pressure drop across the venturi with a digital meter. Determine flow rate by use of venturi Cv performance curves on page 4 or the Anvil Balancing Slide Rule.
14. The handle of the GBV is not designed to be removable. Do not try to take it off the valve, or it may become damaged. If for any reason, the handle is damaged, replace the entire handle assembly with the appropriate replacement part indicated in the table below.

Table 1

PART NUMBER	SIZE
571155-022	$\frac{1}{2}$ "
571155-022	$\frac{3}{4}$ "
571155-022	1"
571155-022	$1\frac{1}{4}$ "
571155-022	$1\frac{1}{2}$ "
571155-022	2"

MEMORY SETTING:

15. After valve has been properly adjusted and without moving the handwheel, the locking memory stop should be set. The memory stop will allow the valve to be fully closed for isolation and then reopened to the preset flow position.
16. Insert a 2.5 mm (or $\frac{3}{32}$ ") Allen key through the hole provided in the valve's handle cap. (Fig. 6)
17. Turn the setscrew in a clockwise direction until it stops. It is not necessary to tighten. The memory has now been set. This establishes the maximum opening position for this particular valve.
18. The valve may now be closed tightly, as needed, for isolating the piping during system maintenance. To return the valve to its preset “balanced” position, simply open the valve by turning the handwheel counter-clockwise until the handle stops turning (the valve stem inside the handle has hit the memory setscrew). **DO NOT APPLY EXCESSIVE FORCE WHEN REOPENING THE VALVE – OPEN ONLY UNTIL THE VALVE STOPS TURNING UNDER “HAND TIGHT” CONDITIONS. DO NOT USE A WRENCH TO OPEN, CLOSE, OR TIGHTEN VALVES.**

Circuit Balancing Valves (Solder), Five Turn GBV-S

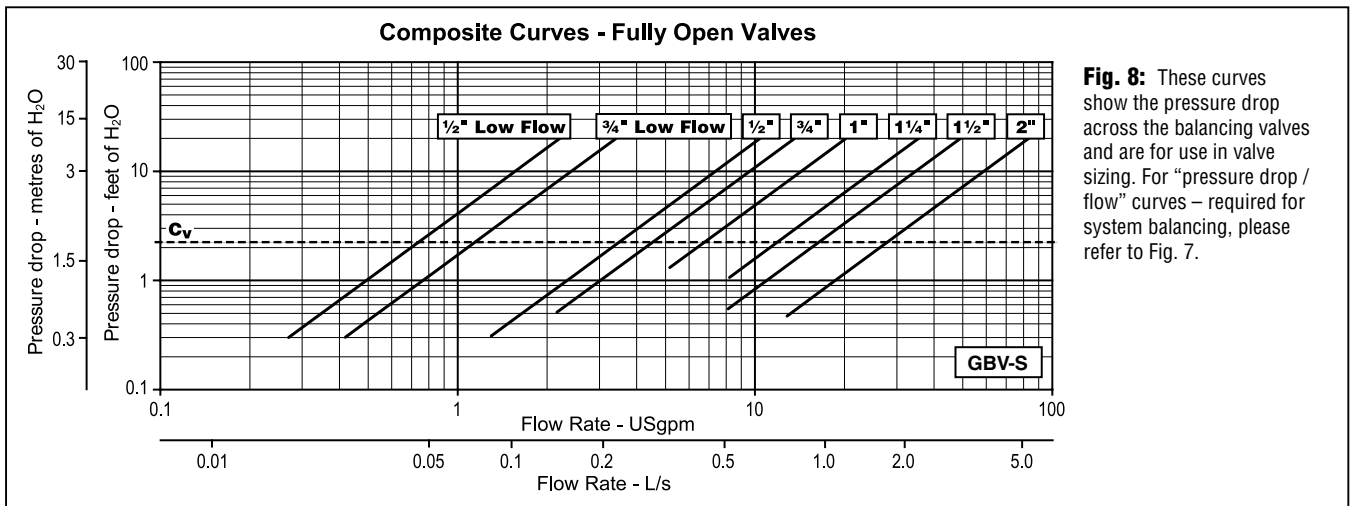
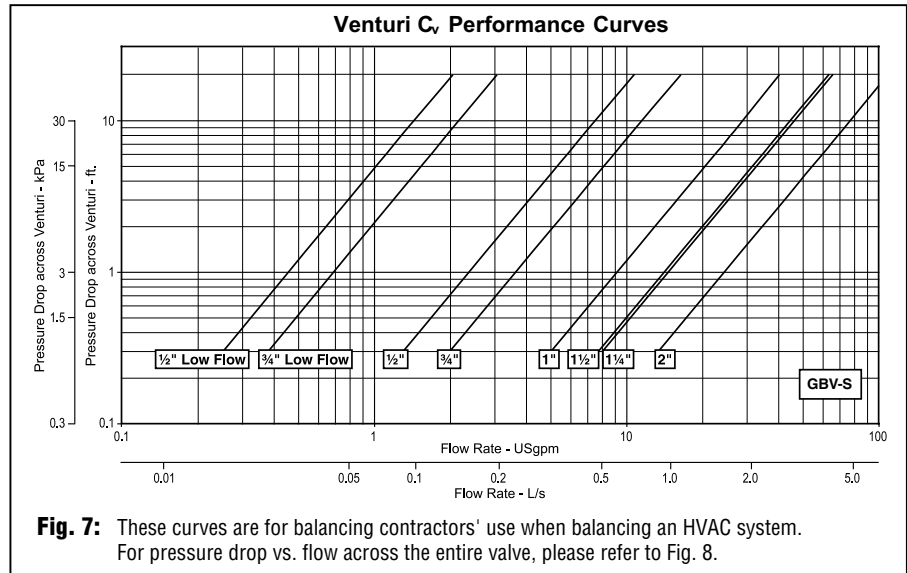
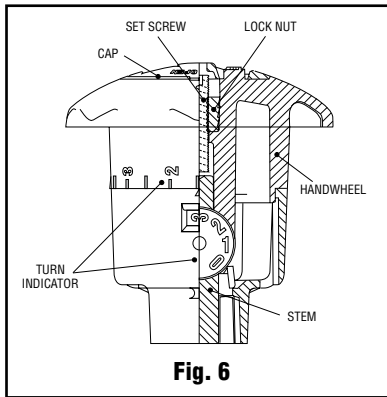

TROUBLESHOOTING:

Symptom	Likely Cause	Solution
1. Valve is leaking:		
• At the bonnet / body joint	Bonnet O Ring has been damaged.	Remove the handle / stem assembly and replace with the appropriate replacement part indicated in Table 1.
• At the pipe connection	If solder joint - the joint has failed, or was not soldered properly.	Re-solder the connection and recheck for leakage.
	If threaded - the connection is not sufficiently tight, or the valve was over-tightened during installation and the valve body has cracked (fractured).	Tighten and recheck for leakage. Remove and reinstall a new valve, being careful not to over-tighten.
2. Valve does not shut off completely when closed (hand tight).	The seat O ring has been deformed due to overheating during soldering.	Remove the handle / stem assembly and replace with the appropriate replacement part indicated in Table 1.

NORTHERN REGION

Regional Distribution & Customer Service Center
750 Central Avenue
University Park, IL 60484
Tel: 708-885-3000 • Fax: 708-534-5441
Toll Free: 1-800-301-2701

SOUTHERN REGION

Regional Distribution & Customer Service Center
1401 Valley View Lane, Suite 150
Irving, TX 75061
Tel: 972-871-1206 • Fax: 972-641-8946
Toll Free: 1-800-451-4414