

Fig. 255

Pipe Alignment Guide

Size Range: 1" through 24" pipe and insulation thickness of 1" through 4"
(Also available in copper tube sizes, see page PH-20)

Material: Carbon steel

Finish: Plain or Galvanized

Service: For maintaining alignment of piping through its axial expansion and contraction cycles. Normally, two or more pipe alignment guides are used on a single piping run to avoid a pivoting effect within the piping system. It is recommended that the first guide be located a maximum of four pipe diameters from an expansion joint. The second guide should be placed a maximum of 18 pipe diameters from an expansion joint. Additional guides should be employed in accordance with the guide spacing data shown on next page. Supports are usually required between the intermediate guides to comply with standard support practice.

Maximum Temperature: 650° F

Installation:

- (1) Attach outer housing to structure by bolting or welding.
- (2) Remove upper section of housing to open position.
- (3) Attach spider clamp to pipe and completely insulate.
- (4) Set pipe and spider clamp into outer housing.
- (5) Replace upper section of housing to closed position and secure.

Note: Spider attachments to pipe must be properly located during installation to insure that a minimum of one-half the spider width remains within the length of the outer housing for all conditions of operation. See table on opposite page for maximum recommended travels. If larger travels are required, special guides can be furnished to special order.

How to size: Size by nominal pipe size and insulation thickness in accordance with the selection table on the opposite page.

Ordering: Specify size number, pipe size, insulation, thickness, figure number, name and finish.

Caution: Guides are designed to carry 20% of the dead weight load. Dead weight load is defined as maximum span of water filled pipe.

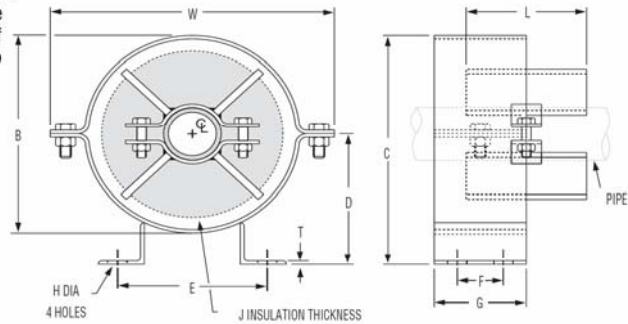

**Pipe Alignment Guide
Figure 255, Size A&B**

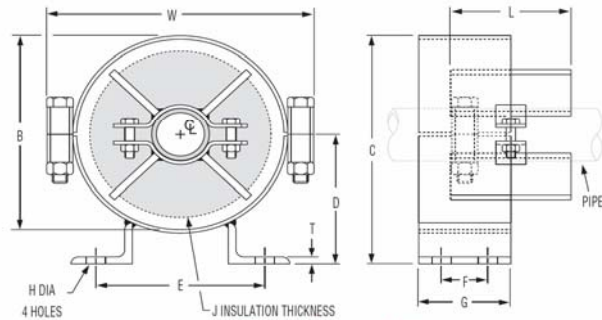

**Pipe Alignment Guide
Figure 255, Size C Thru J**

Pipe Size (in)	L (in)	Maximum Movement
1" to 6"	4	4
8" to 16"	6	6
18" to 24"	8	8

Dimensional Data on Following Page



International Seismic Application Technology!
14848 East Northam Street, La Mirada, CA 90638
877-999-4728(Toll Free) 714-522-0845(Fax)
www.isatsb.com

W V Jaeger

Model Law Structural Engineer
NCEES No.20675

Rev. 0
11/1/06

Page
H5.30A

Fig. 255

Pipe Alignment Guide (cont.)

Pipe Size	Guide Size Number					
	Insulation Thickness (in)					
	1	1½	2	2½	3	4
1						
1¼	A	A	A	B	B	C
1½						
2	B	B	B	C	C	D
2½						
3						
3½						
4	C	C	C	D	D	E
5						
6	D	D	D	D	E	F
8	-	E	E	E	E	
10	-	F	F	F	F	G
12	-					
14	-					
16	-		G	G	G	
18	-					
20	-				H	H
24	-				J	J

Guide Size Selection Table									
Locate bare nominal pipe size in appropriate insulation thickness column and read guide size from "Guide Size No." column to the left.									
Guide Size No.	Dimensions (in)								
	W	B	C	D	E	F	G	H	T
A	8 ¹³ / ₁₆	6 ³ / ₄	8 ⁷ / ₈	4 ⁵ / ₁₆	6 ³ / ₄	2½	4	5/8	1/4
B	10 ¹³ / ₁₆	8 ³ / ₄	9 ⁷ / ₈	5 ⁵ / ₁₆	7 ³ / ₈				
C	13 ⁵ / ₁₆	11¼	12 ⁷ / ₁₆	6 ⁵ / ₈	7 ⁷ / ₈				
D	15 ⁷ / ₈	13 ³ / ₈	14 ¹³ / ₁₆	7 ¹⁵ / ₁₆	9¾	4	6	3/4	5/16
E	18	15½	17 ¹ / ₁₆	9 ¹ / ₈					
F	22¼	19¾	21 ¹ / ₁₆	11	14 ¹ / ₈	5½	8	1	3/8
G	28	25	26¼	13 ⁹ / ₁₆	15 ⁷ / ₈				
H	32 ³ / ₈	29¼	30 ³ / ₄	15 ⁷ / ₈	16 ³ / ₈				
J	37 ⁵ / ₈	34½	36 ¹ / ₈	18 ⁵ / ₈	17 ¹ / ₈				

Pipe Size* (in)	Maximum Distance (feet) Between Intermediate Guides for Pressure (psig)									
	50	100	150	200	250	300	350	400	500	600
3	38	27	22	20	18	17	15	14	13	12
4	52	37	32	27	25	23	22	19	17	16
6	66	47	40	35	31	28	27	25	23	20
8	85	62	51	45	40	36	35	32	29	27
10	103	75	62	54	50	45	42	40	35	32
12	118	85	70	60	55	50	46	43	40	35
14	120	87	72	62	57	52	48	45	41	37
16	130	95	78	68	61	57	52	49	45	41
18	145	105	87	75	68	62	58	55	50	45
20	155	110	92	90	73	68	62	58	53	49
24	180	128	105	90	83	75	70	65	60	54

* For pipe sizes not shown refer to the Expansion Joint Manufacturers Association Guidelines



International Seismic Application Technology
 14848 East Northam Street, La Mirada, CA 90638
 877-999-4728(Toll Free) 714-522-0845(Fax)
 www.isatsb.com

W V Jaeger

Model Law Structural Engineer
 NCEES No.20675

Rev. 0
 11/1/06

Page
H5.30B